

DT4-B266

パーツブック

PARTS BOOK

TEILEKATALOG

LIVRE DES PIECES

LIBRO DE REFERENCIA DE PIEZAS

箱型1本針二重環縫自動糸切りミシン

FLAT BED SINGLE NEEDLE DOUBLE CHAIN STITCHER WITH THREAD TRIMMER

EINNADEL-FLACHBETT-DOPPELKETTENSTICHMASCHINE MIT
FADENABSCHNEIDER

MACHINE POINT DE CHAINETTE A PLATEAU - 1 AIGUILLE AVEC COUPE-FIL

RECUBRIDORA PLANA, UNA AGUJA CON CORTAHILOS

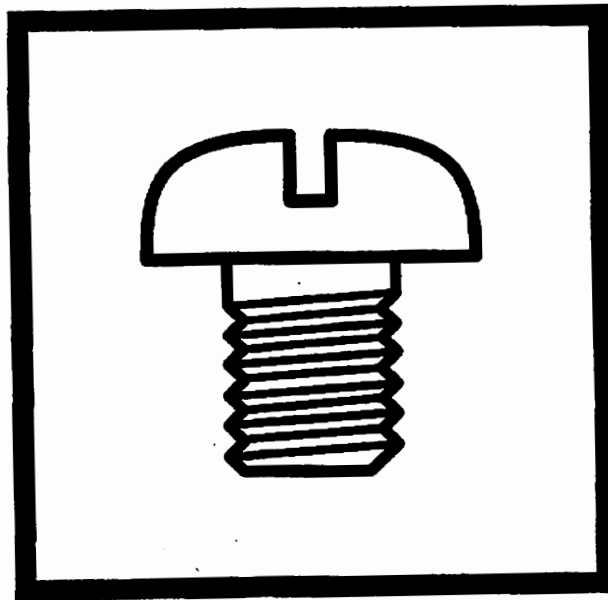

P266001

brother.

Notes for using this parts book

1. This book is applicable to sewing machines which have the same plate number as shown on the cover of this book (or correction sheet).
2. This book was prepared based on information available in December 1997.
3. Parts are subject to changes in design without prior notice.
4. Parts supplied as complete assemblies are circled by a dotted line [-----].
5. If the symbol ※ is found in the "Parts No." column, refer to the different parts list on page 43.

CONTENTS

A. Machine body	1
B. Upper shaft and needle bar mechanism	5
C. Needle cooler	7
G. Synchronizer	7
D. Presser foot mechanism	9
E. Feed mechanism	13
H. Lower shaft mechanism	17
J. Looper mechanism	19
K. Lubrication	21
L. Thread wiper mechanism	25
M. Thread tension	27
N. Lower thread trimmer mechanism	31
P. Presser foot lifting solenoid set	35
Q. Pneumatic presser foot lifting mechanism	37
Z. Accessories	39
GAUGE PARTS LIST	43
INDEX	44

Hinweise zur Verwendung dieser Teileliste

1. Dieses Buch bezieht sich auf die Nähmaschinen mit derselben Kennungsnummer wie auf diesem Buchumschlag (oder auf dem Korrekturblatt).
2. Dieses Buch basiert auf den Informationen vom Dezember 1997.
3. Modelländerungen sind vorbehalten.
4. Die Teile, die als kompletter Satz geliefert werden, sind mit einer [-----] gestrichelten Linie umrandet.
5. Dieses Zeichen ※ in der Spalte "Parts No. (Teil-nummer)" verweist auf die Gesonderte Stückliste auf Seite 43.

INHALTSVERZEICHNIS

A. Maschinengehäuse	1
B. Obere Welle und Nadelstangenvorrichtung	5
C. Nadelkühlungsvorrichtung	7
G. Synchronisator	7
D. Stoffdrückerfuß	9
E. Transportvorrichtung	13
H. Untere Welle	17
J. Greifer	19
K. Schmierung	21
L. Fadenwischvorrichtung	25
M. Fadenspannung	27
N. Untere fadenabschneider	31
P. Solenoidsatz für die anhebung des stoffdrückerfußes	35
Q. Pneumatische stoffdrückerfußanhebevorrichtung	37
Z. Zubehör	39
LEHRENLISTE	43
VERZEICHNIS	44

パーツブックご利用に際して

1. この本は、この本の表紙(正誤表の挿入されている場合は正誤表)に記載されているものと同じプレートが取り付けられているミシンのためのものです。
2. この本は、1997年12月のデータに基づいて作成されたものです。
3. 部品は予告なしに設計変更される場合があります。
4. 組単位で補給する部品は、[] 破線で示しております。
5. 部品コード欄が※となっている場合は、仕様別部品一覧表(43ページ)でお調べ下さい。

目 次

A. 主体関係	1
B. 上軸・針棒関係	5
C. 針冷却関係	7
G. 針位置検出器関係	7
D. 押エ関係	9
E. 送り関係	13
H. 下軸関係	17
J. ルーパー関係	19
K. 給油潤滑関係	21
L. 糸払い関係	25
M. 糸調子関係	27
N. 下飾り糸切り関係	31
P. 電磁押エ上ゲ関係	35
Q. エアー押エ上ゲ関係	37
Z. 付属品関係	39
ゲージ部品一覧表	43
索引	44

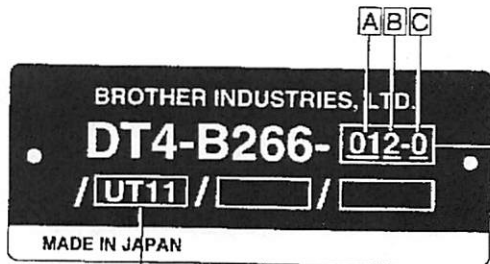

A	送り方式 Feed method
01	一枚送り Uniform feed
0D	差動送り Differential feed

B	仕様 Specifications
2	中厚物用標準ゲージ Standard gauge for medium-thick materials

C	針数 No. of needles
0	一本針 Single needle

D	付属装置 / Devices			
	UT11	UT13	UT21	UT23
電磁式糸切り Solenoid -type thread trimmer	○	○	/	/
エア-式糸切り Pneumatic-type thread trimmer	/	/	○	○
電磁式押え上げ Solenoid -type presser foot lifter	/	○	/	/
エア-式押え上げ Pneumatic-type presser foot lifter	/	/	/	○

Notes sur l'utilisation de ce manuel de pièces détachées

1. Ce manuel est destiné aux machines à coudre ayant le même numéro de plaque montré sur la couverture de ce manuel (ou sur la feuille de corrections).
2. Ce manuel a été fait d'après les renseignements valables au mois de Décembre 1997.
3. Les pièces peuvent être sujettes à des modifications sans préavis.
4. Les pièces fournies en tant qu'assemblages complets sont encadrées avec un trait pointillé [-----].
5. Si le symbole ※ se trouve dans la colonne "Parts No. (N° de pièce)" veuillez la vous référer à la liste de pièces annexe page 43.

TABLE DES MATIERES

A. Corps de la machine	1
B. Mécanisme de arbre supérieur et barra à aiguille	5
C. Mécanisme du refroidisseur d'aiguille	7
G. Synchronisateur	7
D. Mécanisme de pied presseur	9
E. Mécanisme de l'entraînement ..	13
H. Mécanisme de l'arbre inférieur .	17
J. Mécanisme des griffes	19
K. Lubrification	21
L. Mécanisme de tire-fil	25
M. Tension du fil	27
N. Mécanisme de coupe-fils inférieur	31
P. Jeu de solénoïde du releveur du pied pressur	35
Q. Dispositif pneumatique de releveur de pied presseur	37
Z. Accessoires	39
LISTE DES PIECES D'ECARTEMENT	43
INDEX	44

Notas para usar este Manual de Piezas

1. Este libro sirve para todas las máquinas de coser que llevan la misma placa de identificación que la que se puede ver en la tapa de este libro (o en la hoja de erratas).
2. Este libro ha sido compilado basándose en los datos de que se disponía en diciembre 1997.
3. Las piezas quedan sujetas a cambios de diseño sin aviso previo.
4. Las piezas suministradas como conjuntos completos se enmarcan con una línea punteada [-----].
5. De haber un símbolo ※ junto al "Parts No. (Número de Pieza)", habrá que mirar la lista de piezas separada de la página 43.

INDICE

A. Cuerpo de la máquina	1
B. Mecanismo del eje superior y la barra de aguja	5
C. Mecanismo del enfriador de aguja	7
G. Sincronizador	7
D. Mecanismo de la prensa tela	9
E. Mecanismo de la alimentación ..	13
H. Mecanismo del eje inferior	17
J. Mecanismo del presilladora	19
K. Lubricación	21
L. Mecanismo del limpiador de hilo	25
M. Tensión del hilo	27
N. Dispositivo de cortahilos inferior	31
P. Conjunto solenoide del levantador	35
Q. Levantador neumático del prensatelas	37
Z. Accesorios	39
PIEZAS DE CALIBRADORES	43
INDICE	44

A. 主体関係 / Machine body / Maschinengehäuse / Corps de la machine / Cuerpo de la máquina

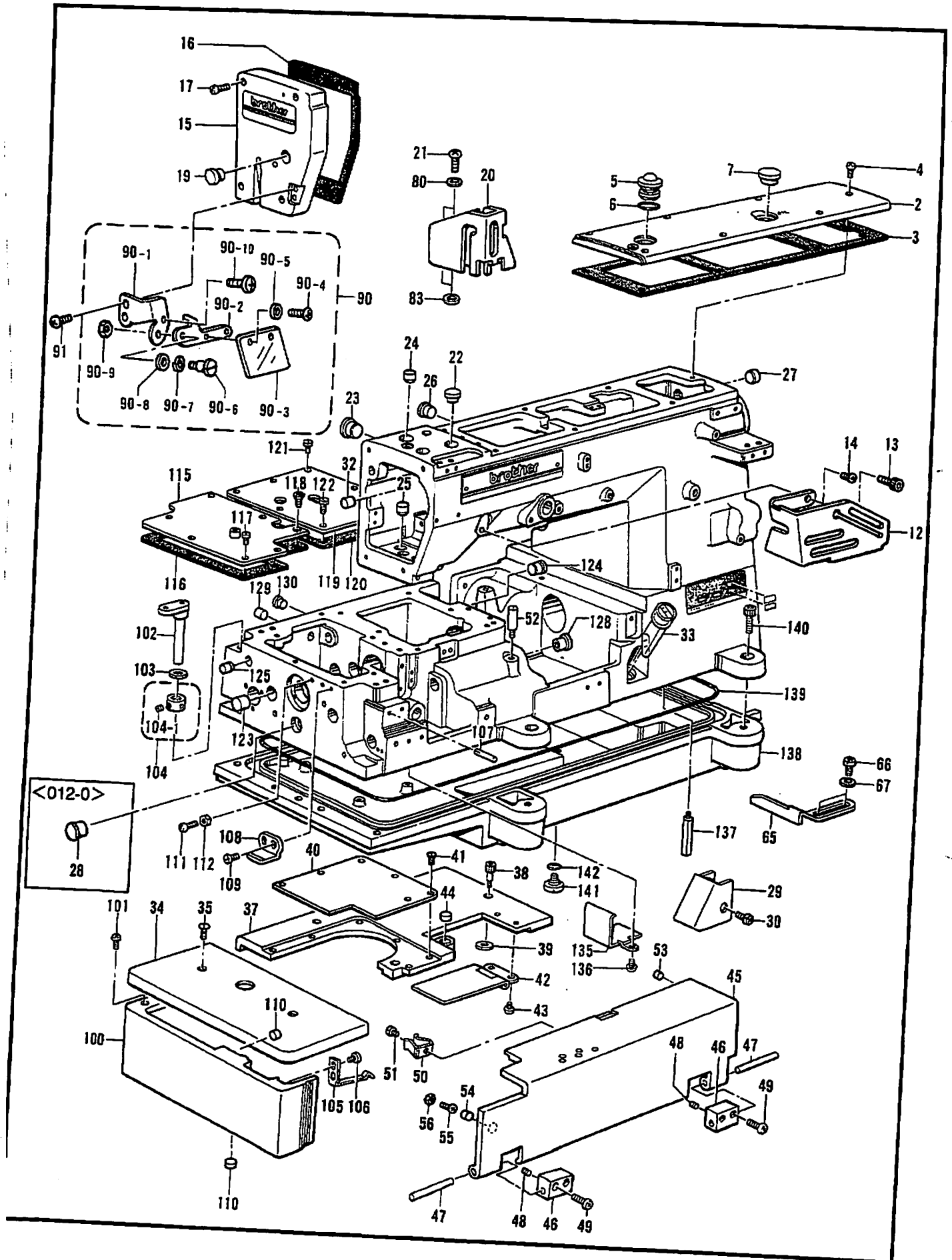

A. 主体関係 / Machine body / Maschinengehäuse / Corps de la machine / Cuerpo de la máquina

REF.NO.	CODE	Q'TY	品名	NAME OF PARTS	RM
2	S08627001	1	ウフフタ	TOP COVER	
3	S08628000	1	ウフフタパツキン	TOP COVER PACKING	
4	062681012	7	ナベコ437-40X10	SCREW, PAN SM4.37-40X10	
5	S02606000	1	ユリヨウケイマド	OIL GAUGE WINDOW	
6	081014670	1	OリングPW14	O RING, PW14	
7	159150009	1	ゴムセン20.5	RUBBER CAP, 20.5	
12	S40532001	1	ハリイトクリカバー	NEEDLE THREAD TAKE-UP COVER	
13	018060822	1	アナボルト6X8	BOLT, SOCKET M6X8	
14	S10774001	1	ナベコ437-40X7	SCREW, PAN M4.37-40X7	
15	S28810051	1	メンイタ	FACE PLATE	
16	S08631000	1	メンイタパツキン	FACE PLATE PACKING	
17	062681612	4	ナベコ437-40X16	SCREW, PAN SM4.37-40X16	
19	117934009	1	ゴムセン13.5	RUBBER CAP, 13.5	
20	S28809201	1	ハリボウテンピンカバー	NEEDLE BAR TAKE-UP COVER	
21	062681012	2	ナベコ437-40X10	SCREW, PAN SM4.37-40X10	
22	104449009	1	ゴムセン15.5	RUBBER CAP, 15.5	
23	104450109	2	ゴムセン8	RUBBER CAP, 8	
24	154841009	1	ゴムセン16.8	RUBBER CAP, 16.8	
25	154841009	1	ゴムセン16.8	RUBBER CAP, 16.8	
26	108520009	1	ゴムセン19.8	RUBBER CAP, 19.8	
27	S00313009	1	ゴムセン16.8	RUBBER CAP, 16.8	
29	S08633101	1	シタイトカバー	BOBBIN THREAD COVER	
30	062680812	1	ナベコ437-40X8	SCREW, PAN SM4.37-40X8	
32	156887001	1	ゴムセン17.5	RUBBER CAP, 17.5	
33	148084001	1	オイルゲージマド	OIL GAUGE WINDOW	
34	S21813051	1	クロスプレートL	CLOTH PLATE (L)	
35	100032004	2	サラネジ4.37	SCREW, FLAT SM4.37	
37	S21814001	1	クロスプレートR	CLOTH PLATE (R)	
38	S09123101	3	アナボルト4.37X15	BOLT, SOCKET M4.37X15	
39	S08639000	1	クロスプレートパツキン	CLOTH PLATE PACKING	
40	S21815001	1	スベリイタ	SLIDER PLATE	
41	102843004	6	サラネジ3.57	SCREW, FLAT SM3.57	
42	S08642001	1	シタイトテンピンカバークミ	LOOPER THREAD TAKE-UP COVER ASSY	
43	123185001	2	マルヒラネジ3.57X4.5	SCREW, OVAL M3.57X4.5	
44	S08646100	1	マグネット	MAGNET	
45	S21816001	1	マエカバー	FRONT COVER	
46	S08651001	2	マエカバーササエ	FRONT COVER SUPPORT	
47	S08652000	2	マエカバーササエジク	FRONT COVER SUPPORT SHAFT	
48	153675001	2	アナトメネジ4.37	SET SCREW, SOCKET SM4.37	
49	060681612	4	バインド437-40X16	SCREW, BIND SM4.37-40X16	
50	114985001	1	ベツトカバートメバネ	SPRING, PLATE	
51	062680612	1	ナベコ4.37-40X6	SCREW, PAN SM4.37-40X6	
52	S08653001	1	バネウケネジ	SCREW	
53	142274009	2	ゴムセン4.2	RUBBER CAP, 4.2	
54	146586009	1	ゴムセン11	RUBBER CAP, 11	
55	062681412	1	ナベコ437-40X14	SCREW, PAN SM4.37-40X14	
56	105234003	1	ナツト4.37	NUT, SM4.37	
65	S40535001	1	ヌノガイド	CLOTH GUIDE	
66	062710812	2	ナベコ476-32X8	SCREW, PAN SM4.76-32X8	
67	146354001	2	ザガネ	WASHER, PLAIN 5	
80	100645003	2	ザガネ	WASHER	
83	025680133	2	ヒラザガネシヨウウ4.37	WASHER, PLAIN S 4.37	
90	S28802001	1	アイガードクミ	EYE GUARD ASSY	
90-1	S28803001	1	アイガードドダイ	EYE GUARD BASE	
90-2	S28804001	1	アイガードトリツケイタ	EYE GUARD SETTING PLATE	
90-3	S00075000	1	アイガード	EYE GUARD	
90-4	062660512	2	ナベコネジ318-40X5	SCREW, PAN SM3.18-40X5	
90-5	025030232	2	ヒラザガネチユウ3	WASHER, PLAIN M 3	
90-6	S07317001	1	ダンネジ3.57	SHOULDER SCREW, SM3.57	

118-266-052

A. 主体関係 / Machine body / Maschinengehäuse / Corps de la machine / Cuerpo de la máquina

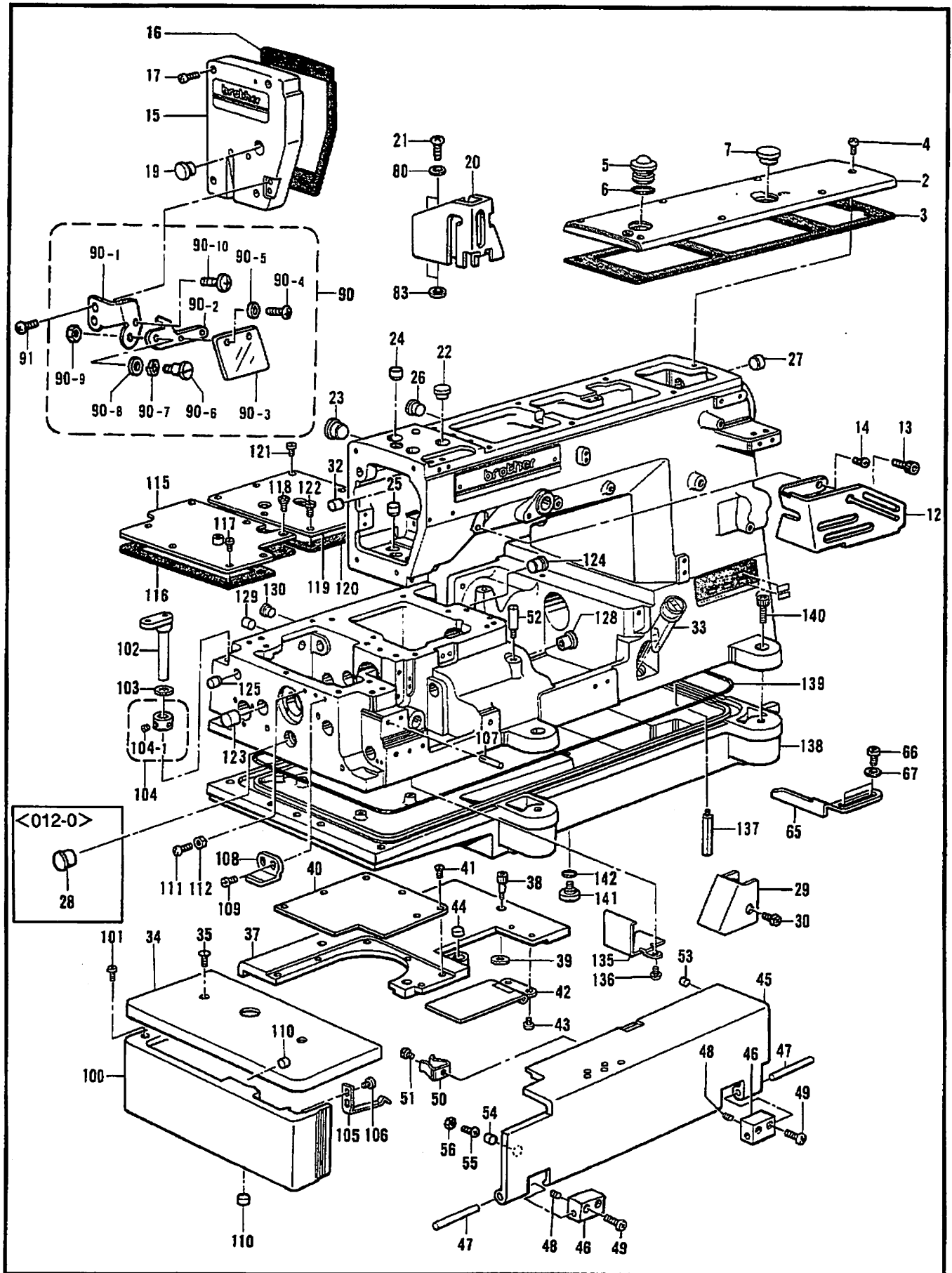

118-266-052

A. 主体関係 / Machine body / Maschinengehäuse / Corps de la machine / Cuerpo de la máquina

REF.NO.	CODE	Q'TY	ヒンメイ	NAME OF PARTS	RM
90-7	028050246	1	バネザガネ2-5	WASHER, SPRING 2-5	
90-8	025050232	1	ヒラザガネチユウ5	WASHER, PLAIN M 5	
90-9	106129001	1	ナツト3.57	NUT, SM3.57	
90-10	060670512	1	バインド357-40X5	SCREW, BIND SM3.57-40X5	
91	060680712	2	バインド437-40X7	SCREW, BIND SM4.37-40X7	
100	S08665001	1	ヨコカバー	SIDE COVER	
101	062680812	2	ナベコ437-40X8	SCREW, PAN SM4.37-40X8	
102	S00017001	1	クロスプレートササエジク	CLOTH PLATE SUPPORT SHAFT	
103	141183000	1	クロスプレートシート	CLOTH PLATE SHEET	
104	183893001	1	セットカラークミ	SET SCREW COLLAR ASSY	
104-1	101706001	2	トメネジ6.35	SET SCREW, SM6.35	
105	S08667001	1	ヨコカバートメイタバネ	PLATE SPRING	
106	060680712	2	バインド437-40X7	SCREW, BIND SM4.37-40X7	
107	140063001	1	ミヅツキピン	DOWEL PIN	
108	S08668001	1	ヨコカバーガイド	SIDE COVER GUIDE	
109	107407003	2	シメネジ4.37	SCREW, SM4.37	
110	146586009	2	ゴムセン11	RUBBER CAP, 11	
111	062681012	1	ナベコ437-40X10	SCREW, PAN SM4.37-40X10	
112	105234003	1	ナツト4.37	NUT, SM4.37	
115	S40533001	1	オクリキコウカバー	FEED MECHANISM COVER	
116	S08670000	1	オクリキコウカバーパツキン	FEED MECHANISM COVER PACKING	
117	107407003	6	シメネジ4.37	SCREW, SM4.37	
118	151267001	1	サラネジ4.37	SCREW, FLAT SM4.37	
119	S21959001	1	ベッドウワカバー	BED UPPER COVER	
120	S08672000	1	ベッドウワカバーパツキン	BED UPPER COVER PACKING	
121	107407003	2	シメネジ4.37	SCREW, SM4.37	
122	117516001	1	ボルト4.37	BOLT, M4.37	
123	S00313009	1	ゴムセン16.8	RUBBER CAP, 16.8	
124	S08673000	1	ゴムセン14	RUBBER CAP, 14	
125	146315009	1	ゴムセン10.7	RUBBER CAP, 10.7	
128	S08673000	1	ゴムセン14	RUBBER CAP, 14	
129	146586009	1	ゴムセン11	RUBBER CAP, 11	
130	104450109	1	ゴムセン8	RUBBER CAP, 8	
135	146457001	1	シキリイタ	OIL STOPPER PLATE	
136	062670612	2	ナベコ357-40X6	SCREW, PAN SM3.57-40X6	
137	151059001	4	ホンタイシチユウ	MACHINE BODY LEG	
138	S08674000	1	アブラウケ	OIL RESERVOIR	
139	S08675000	1	Oリング	O RING	
140	018081622	5	アナボルト8X16	BOLT, SOCKET M8X16	
141	110641002	1	ダンネジ9.52	STUD SCREW, SM9.52	
142	109203001	1	Oリング	O RING	
28	158437009	1	<012-0> ゴムセン10	<012-0> RUBBER CAP, 10	

118-266-052

B. 上軸・針棒関係 / Upper shaft and needle bar mechanism / Obere Welle und Nadelstangenvorrichtung / Mécanisme de arbre supérieur et barra à aiguille / Mecanismo del eje superior y la barra de aguja

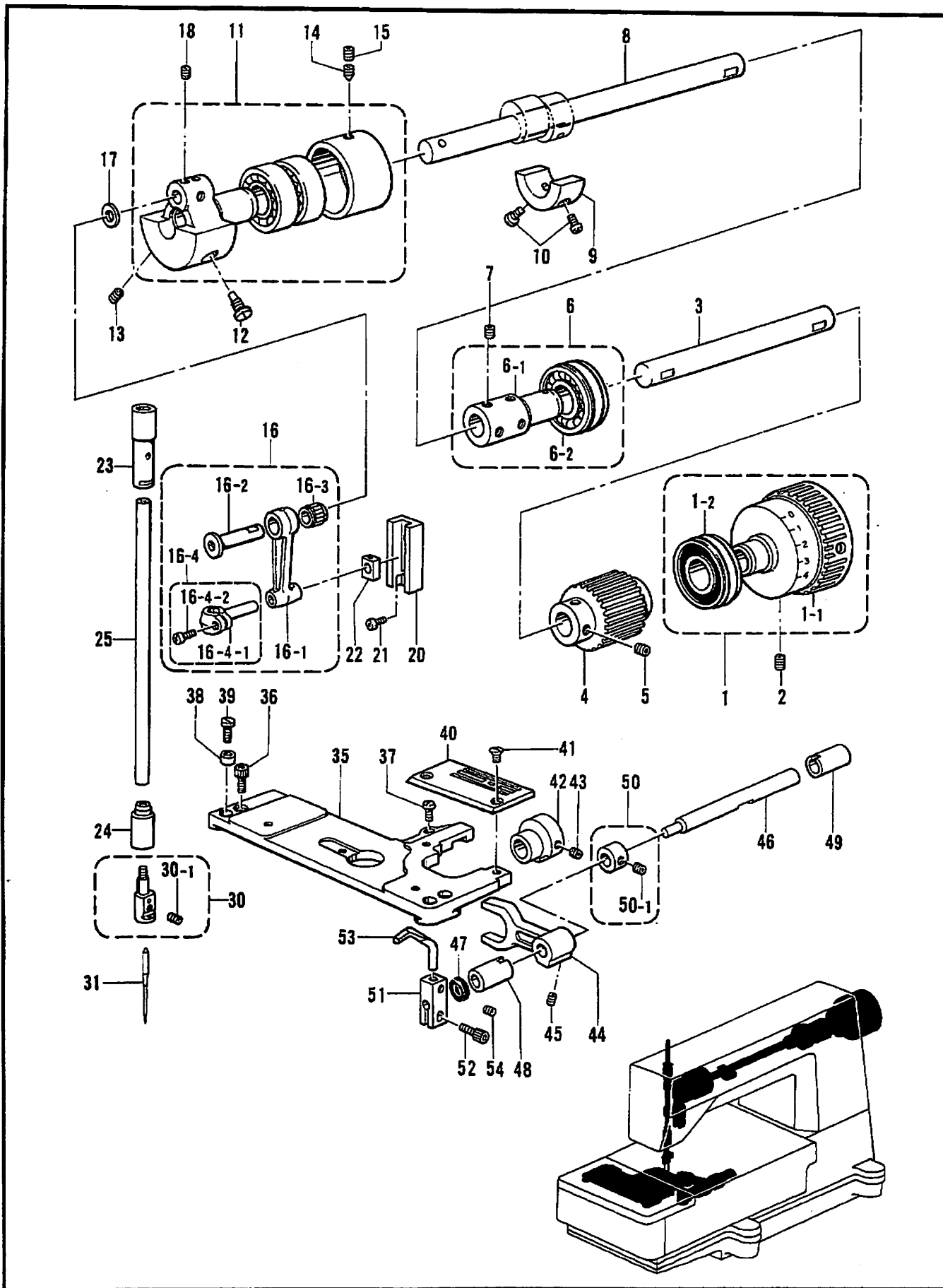

118-266-123

B. 上軸・針棒関係 / Upper shaft and needle bar mechanism / Obere Welle und Nadelstangenvorrichtung / Mécanisme de arbre supérieur et barra à aiguille / Mecanismo del eje superior y la barra de aguaaja

REF.NO.	CODE	Q'TY	ヒンメイ	NAME OF PARTS	RM
1	S28957001	1	プーリクミ	PULLEY ASSY	
1-1	S28958001	1	プーリ	PULLEY	
1-2	S14621001	1	タマジクウケ6204LLB	BALL BEARING, 6204LLB	
2	014770622	2	アナトメネジ6.35クボミ	SET SCREW, SOCKET (CP) SM6.35	
3	S08682001	1	ウワジクR	UPPER SHAFT, R	
4	S08683000	1	タイミングプーリU	TIMING PULLEY, U	
5	014770622	4	アナトメネジ6.35クボミ	SET SCREW, SOCKET (CP) SM6.35	
6	S08684101	1	ツギテLクミ	JOINT ASSY, L	
6-1	S08685001	1	ツギテL	JOINT, L	
6-2	S08686101	1	タマジクウケ6204LU	BALL BEARING, 6204LU	
7	014770622	4	アナトメネジ6.35クボミ	SET SCREW, SOCKET (CP) SM6.35	
8	S08687001	1	ウワジクL	ARM SHAFT (L)	
9	S08688001	1	ウエイト	WEIGHT	
10	062711012	2	ナベコ476-32X10	SCREW, PAN SM4.76-32X10	
11	S08689001	1	テンピンクラッククミ	NEEDLE BAR CRANK ASSY	
12	104464001	1	シメネジ7.14	SCREW, SM7.14	
13	014770622	1	アナトメネジ6.35クボミ	SET SCREW, SOCKET (CP) SM6.35	
14	118853001	1	アナトメネジ5.95	SET SCREW, SOCKET SM5.95	
15	014760622	1	アナトメネジ5.95	SET SCREW, SOCKET SM5.95	
16	S08692101	1	ハリボウレンカンクミ	THREAD TAKE-UP LEVER ASSY	
16-1	S08693001	1	ハリボウレンカン	THREAD TAKE-UP LEVER	
16-2	S08694001	1	ハリボウレンカンジク	THREAD TAKE-UP LEVER SHAFT	
16-3	S09120001	1	ニードルジクウケ	NEEDLE ROLLER BEARING	
16-4	S30086001	1	ハリボウダキクミ	NEEDLE BAR CLAMP ASSY	
16-4-1	S08695001	1	ハリボウダキ	NEEDLE BAR CLAMP	
16-4-2	100064005	1	シメネジ3.57	SCREW, SM3.57	
17	107153001	1	ザガネ	WASHER	
18	014760622	3	アナトメネジ5.95	SET SCREW, SOCKET SM5.95	
20	145688000	1	ハリボウアンナイ	NEEDLE BAR GUIDE	
21	062670612	2	ナベコ357-40X6	SCREW, PAN SM3.57-40X6	
22	102630001	1	ハリボウアンナイカクコマ	NEEDLE BAR GUIDE SLIDE BLOCK	
23	S08696000	1	ハリボウメタルU	NEEDLE BAR BUSH, U	
24	S08697000	1	ハリボウメタルD	NEEDLE BAR BUSH, D	
25	S08698001	1	ハリボウ	NEEDLE BAR	
30	S17480201	1	ハリドメ1クミ	NEEDLE CLAMP ASSY	
30-1	146427001	1	アナトメネジ3.18クボミ	SET SCREW, SOCKET (CP) SM3.18	
31	S08715016	1	ミシンハリUYX128GAS	NEEDLE, UYX128GAS (#16)	
35	S08716301	1	ハリイタササエイタ	SUPPORTER PLATE, NEEDLE PLATE	
36	018681022	2	アナボルト4.37X10	BOLT, SOCKET SM4.37X10	
37	062680812	1	ナベコ437-40X8	SCREW, PAN SM4.37-40X8	
38	S09124001	2	ハリイタササエイタカラー	COLLER	
39	S13385001	2	シメネジ3.57X10	SCREW, SM3.57X10	
40	S40538001	1	ハリイタ	NEEDLE PLATE	
41	S09121001	2	マルサラネジ3.57X6	SCREW, FLAT M3.57X6	
42	S08750001	1	ハリウケBヘンシンリン	NEEDLE GUARD REAR ECCENTRIC WHEEL	
43	014680622	2	アナトメネジ4.37クボミ	SET SCREW, SOCKET (CP) SM4.37	
44	S08751001	1	ハリウケBレバー	NEEDLE GUARD REAR LEVER	
45	014680622	2	アナトメネジ4.37クボミ	SET SCREW, SOCKET (CP) SM4.37	
46	S08752001	1	ハリウケBジク	NEEDLE GUARD REAR SHAFT	
47	155539000	1	ダストシール	DUST SEAL	
48	S08753000	1	ハリウケBジクメタルL	KNIFE DRIVING SHAFT BUSH (L)	
49	S08754000	1	ハリウケBジクメタルR	KNIFE DRIVING SHAFT BUSH (R)	
50	S03704002	1	セツトカラークミ	SET SCREW COLLAR ASSY	
50-1	014770622	2	アナトメネジ6.35クボミ	SET SCREW, SOCKET (CP) SM6.35	
51	S08755101	1	ハリウケBトリツケダイ	NEEDLE GUARD BACK SET BRACKET	
52	018681022	1	アナボルト4.37X10	BOLT, SOCKET SM4.37X10	
53	S08756001	1	ハリウケB	NEEDLE GUARD REAR	
54	014680422	1	アナトメネジ4.37クボミ	SET SCREW, SOCKET (CP) SM4.37	

C. 針冷却關係 / Needle cooler / Nadelkühlungsvorrichtung / Mécanisme du refroidisseur d'aiguille / Mecanismo del enfriador de aguja

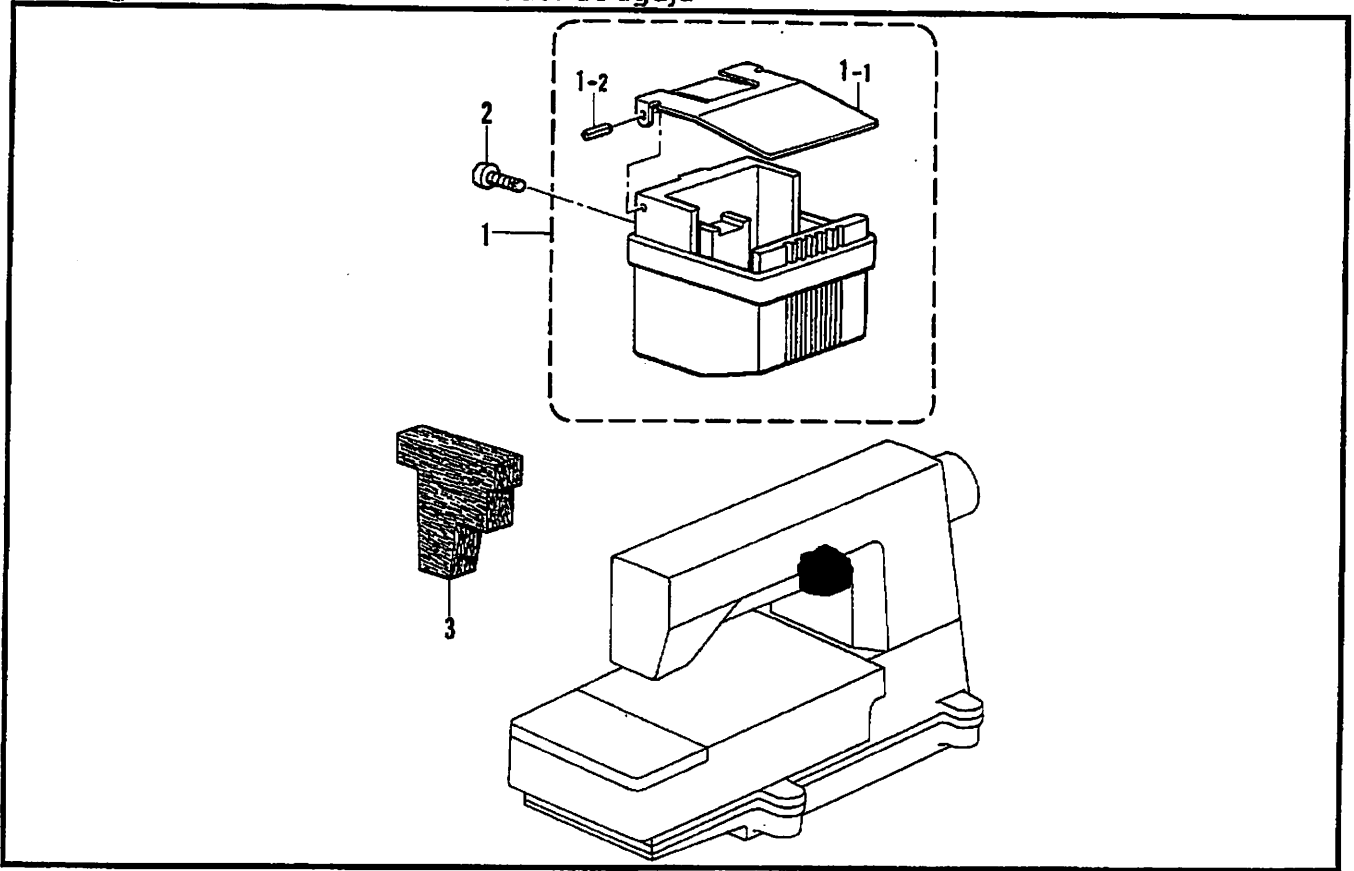

118-266-124

G. 針位置検出器關係 / Synchronizer / Synchronisator / Synchronisateur / Sincronizador

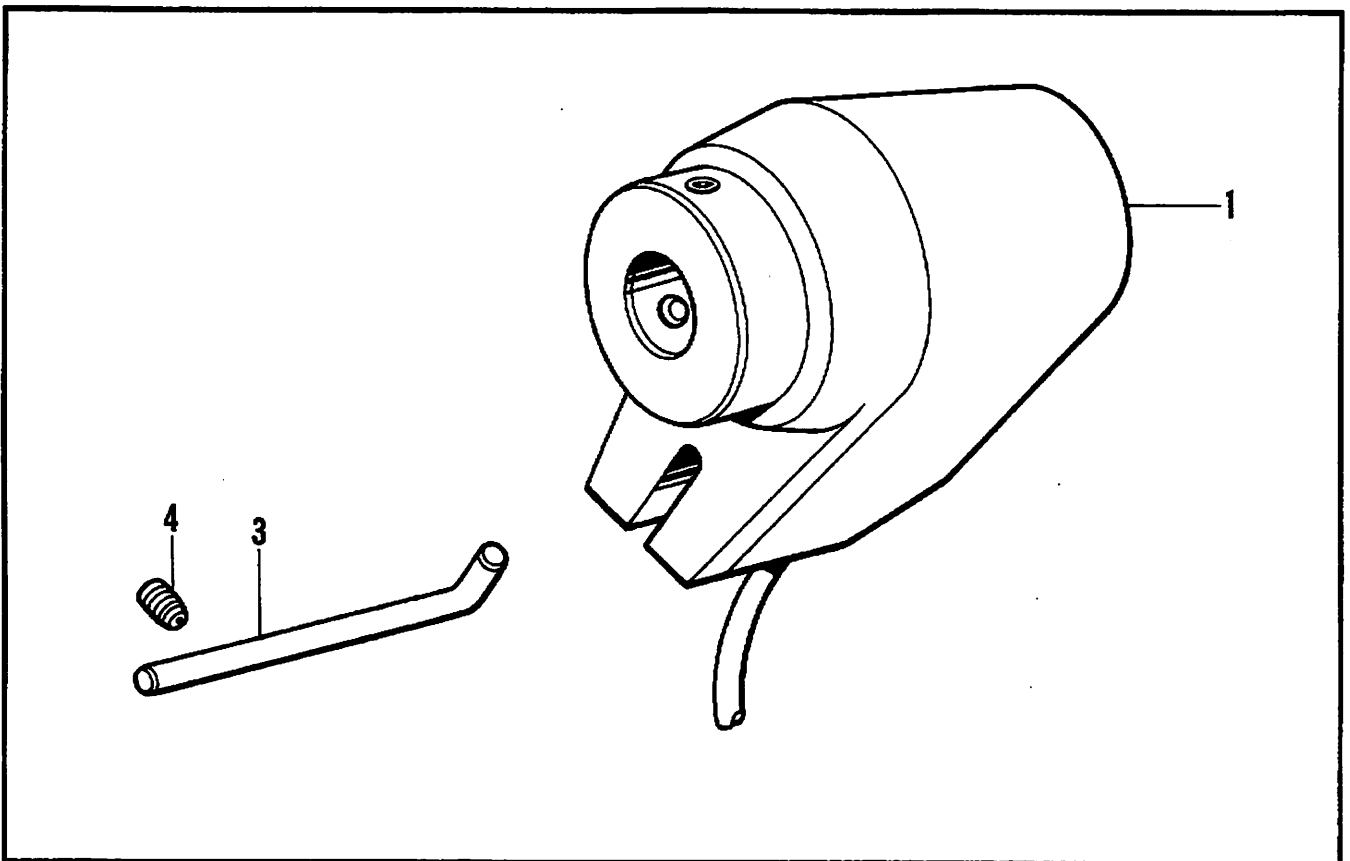

118-266-501

C. 針冷却関係 / Needle cooler / Nadelkühlungsvorrichtung / Mécanisme du refroidisseur d'aiguille / Mecanismo del enfriador de aguja

REF.NO.	CODE	Q'TY	ヒンメイ	NAME OF PARTS	RM
1	S08758109	1	ハライトレイキヤクタンククミ	NEEDLE THREAD COOLER TANK ASSY	
1-1	S08760009	1	ハライトレイキヤクタンクフタ	N/THREAD COOLER TANK COVER	
1-2	047200642	2	スプリングピンAW2	PIN, SPRING ROLL AW2	
2	087311215	2	カツプBタイト3X12	TAPTITE, CUP B M3X12	
3	S08761100	1	ハライトレイキヤクフェルト	FELT	

118-266-124

G. 針位置検出器関係 / Synchronizer / Synchronisator / Synchronisateur / Sincronizador

REF.NO.	CODE	Q'TY	ヒンメイ	NAME OF PARTS	RM
1	J80347001	1	シンクロナイザ#17-2ホ	SYNCHRONIZER #17-2	
3	S28963001	1	シンクロナイザガイド	SYNCHRONIZER GUIDE	
4	014680622	1	アナトメネジ4.37クボミ	SET SCREW, SOCKET (CP) SM4.37	

118-266-501

D. 押工関係 / Presser foot mechanism / Stoffdrückerfuß / Mécanisme de pied presseur / Mecanismo de la prensa tela

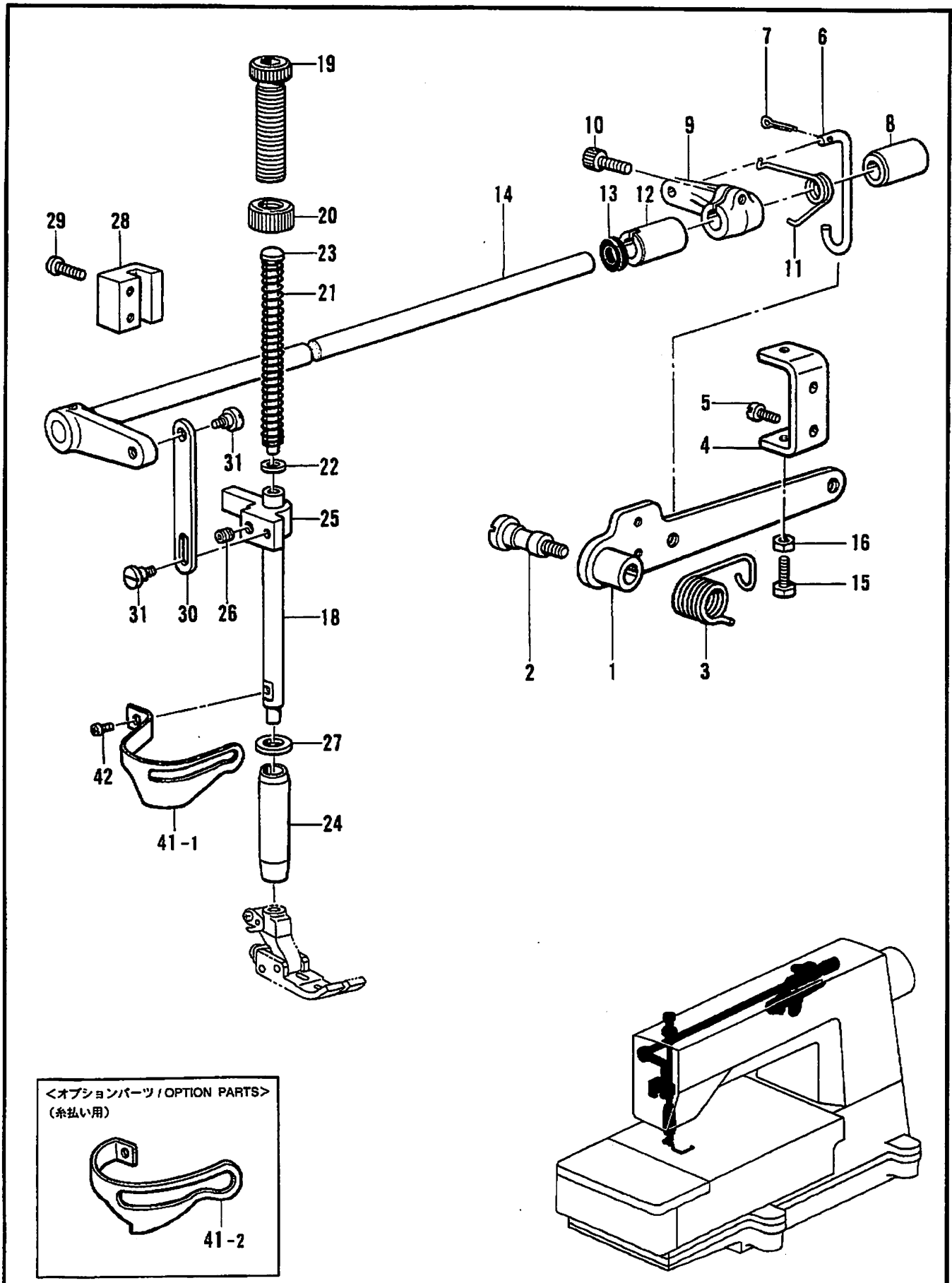

118-266-201

D. 押工関係 / Presser foot mechanism / Stoffdrückerfuß / Mécanisme de pied presseur / Mecanismo de la prensa tela

REF.NO.	CODE	Q'TY	ヒンメイ	NAME OF PARTS	RM
1	S21829001	1	オサエアゲレバーR.	PRESSER BAR LIFTER LEVER (R)	
2	S21830001	1	ダンネジ7.94	STUD SCREW, M7.94	
3	143325001	1	オサエアシアゲレバーバネ	SPRING	
4	146522101	1	レバーチヨウセツイタ	LEVER ADJUST PLATE	
5	060680712	2	バインド437-40X7	SCREW, BIND SM4.37-40X7	
6	S08769001	1	オサエアゲリンク	PRESSER BAR LIFTER LINK	
7	110793001	1	ワリピン	PIN, COTTER	
8	155220000	1	ホジヨアツメタルR	AUTO PRESSER ARM BUSH (R)	
9	154956001	1	オサエアシアゲMレバー	PRESSER FOOT LIFTER INSIDE LEVER	
10	018771432	1	アナボルト635-40X14	BOLT, SOCKET SM6.35-40X14	
11	154957001	1	オサエアゲMレバーバネ	SPRING	
12	S08770000	1	ジクメタル	SHAFT BUSH	
13	155539000	1	ダストシール	DUST SEAL	
14	S08771001	1	オサエアゲレバーLクミ	PRESSER BAR LIFTER LEVER (L) ASSY	
15	017711612	1	ボルト4.76X16	BOLT, SM4.76X16	
16	110161006	1	ナツト4.76	NUT, SM4.76	
18	S08774001	1	オサエボウ	PRESSER BAR	
19	S31012001	1	オサエチヨウセツネジ	PRESSER ADJUSTING SCREW	
20	S31013001	1	チヨウセツネジツマミナツト	PRESSER ADJUSTING NUT	
21	141728001	1	オサエバネ	PRESSER SPRING	
22	140407001	1	ザガネ	WASHER	
23	141208001	1	オサエバネアンナイ	SPRING GUIDE	
24	145472001	1	オサエボウメタル	PRESSER BAR BUSH	
25	S00879001	1	オサエボウダキ	PRESSER BAR CLAMP	
26	014760622	1	アナトメネジ5.95	SET SCREW, SOCKET SM5.95	
27	154596000	1	イトキリカムレバークツシヨン	CUSHION	
28	S08775000	1	オサエボウアンナイ	PRESSER BAR GUIDE	
29	062681412	2	ナベコ437-40X14	SCREW, PAN SM4.37-40X14	
30	S08776001	1	オサエアゲイタ	PRESSER BAR LIFTER PLATE	
31	S08777001	2	ダンネジ4.37	SHOULDER SCREW, M4.37	
41-1	S28798001	1	フィンガーガードA	FINGER GUARD (A)	
42	062670812	1	ナベコ3.57-40X8	SCREW, PAN SM3.57-40X8	
41-2	S28800001	1	"オプションパーツ" <糸払い用> フィンガーガードC	"OPTION PARTS" <FOR THREAD WIPER> FINGER GUARD (C)	

118-266-201

D. 押工関係 / Presser foot mechanism / Stoffdrückerfuß / Mécanisme de pied presseur / Mecanismo de la prensa tela

<012-0、0D2-0>

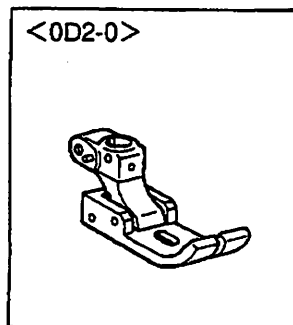
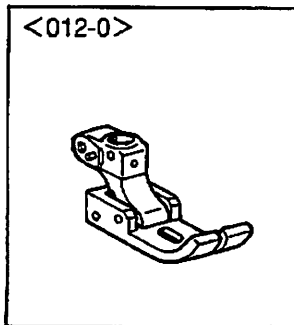
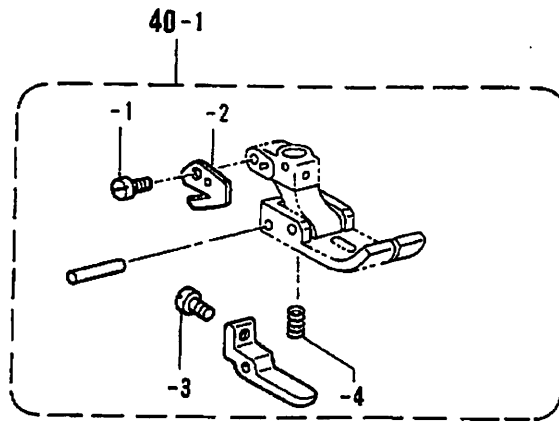

<オプションパーツ / OPTION PARTS>

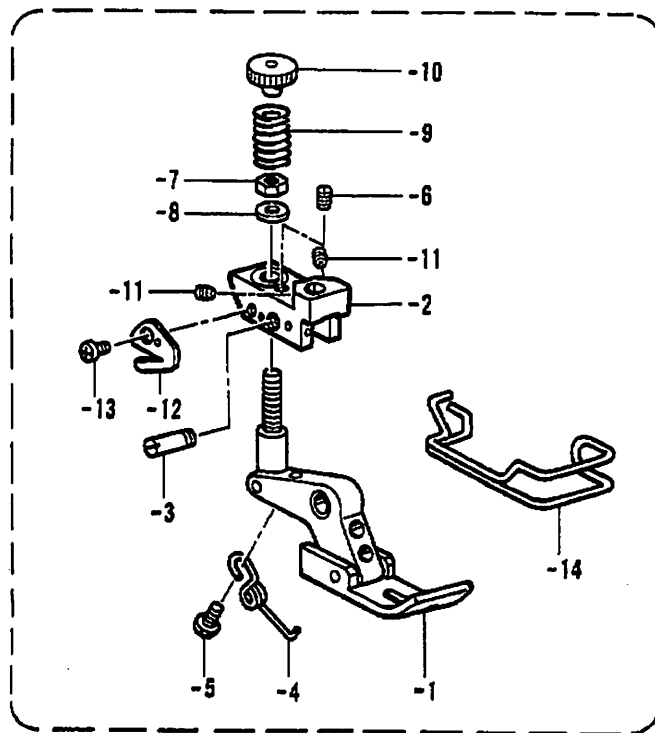
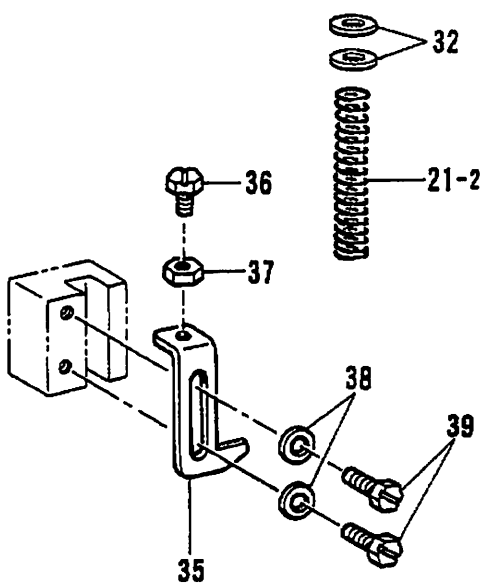

40-2

D. 押工関係 / Presser foot mechanism / Stoffdrückerfuß / Mécanisme de pied presseur / Mecanismo de la prensa tela

REF.NO.	CODE	Q'TY	ヒンメイ	NAME OF PARTS	RM
40-1	※	1	<012-0> オサエクミ	<012-0> PRESSER FOOT ASSY	
40-1-1	062671212	1	ナベコ357-40X12	SCREW, PAN SM3.57-40X12	
40-1-2	S20118151	1	カラヌイメス	TRIMMING KNIFE	
40-1-3	062630612	1	ナベコ238-56X6	SCREW, PAN SM2.38-56X6	
40-1-4	S40546001	1	カラカンオサエバネ	SPRING	
40-1-5	021630102	1	ナツト1シユ2.	NUT, 1 M2	
40-3	※	1	<0D2-0> オサエクミ	<0D2-0> PRESSER FOOT ASSY	
40-3-1	062671212	1	ナベコ357-40X12	SCREW, PAN SM3.57-40X12	
40-3-2	S20118151	1	カラヌイメス	TRIMMING KNIFE	
40-3-3	062630612	1	ナベコ238-56X6	SCREW, PAN SM2.38-56X6	
40-3-4	S40546001	1	カラカンオサエバネ	SPRING	
40-3-5	021630102	1	ナツト1シユ2.	NUT, 1 M2	
32	140407001	2	"オプションパーツ" ザガネ	"OPTION PARTS" WASHER	
35	S40539001	1	オサエボウストツバ	PRESSER BAR STOPPER	
36	154574001	1	ボルト4.37	BOLT, SM4.37	
37	102571003	1	ナツト4.37	NUT, SM4.37	
38	100645003	2	ザガネ	WASHER	
39	117516001	2	ボルト4.37	BOLT, M4.37	
40-2	※	1	Fオサエクミ	F. PRESSER FOOT ASSY	
40-2-1	S40549101	1	Fオサエコグミ	F. PRESSER FOOT BOTTOM ASSY	
40-2-2	S40544101	1	Fオサエシジタイクミ	PRESSER FOOT BASE	
40-2-3	S40555001	1	オサエシジピン	PRESSER FOOT PIN	
40-2-4	S40556001	1	オサエホジバネ	SPRING	
40-2-5	111105002	1	シメネジ2.38	SCREW, SM2.38	
40-2-6	S13085001	1	トメネジ3.18	SET SCREW, SM3.18	
40-2-7	021670202	1	ナツト2シユ3.57	NUT, 2 SM3.57	
40-2-8	105161004	1	ザガネ	WASHER	
40-2-9	S40558001	1	オサエバネ	PRESSER SPRING	
40-2-10	S40557001	1	オサエバネナツト	PRESSER SPRING NUT	
40-2-11	014680422	2	アナトメネジ4.37クボミ	SET SCREW, SOCKET (CP) SM4.37	
40-2-12	S20118151	1	カラヌイメス	TRIMMING KNIFE	
40-2-13	062670412	1	ナベコ357-40X4	SCREW, PAN SM3.57-40X4	
40-2-14	S36894000	1	フィンガーガード	FINGER GUARD	

118-266-201

E. 送り関係 / Feed mechanism / Transportvorrichtung / Mécanisme de l'entraînement / Mecanismo de la alimentación

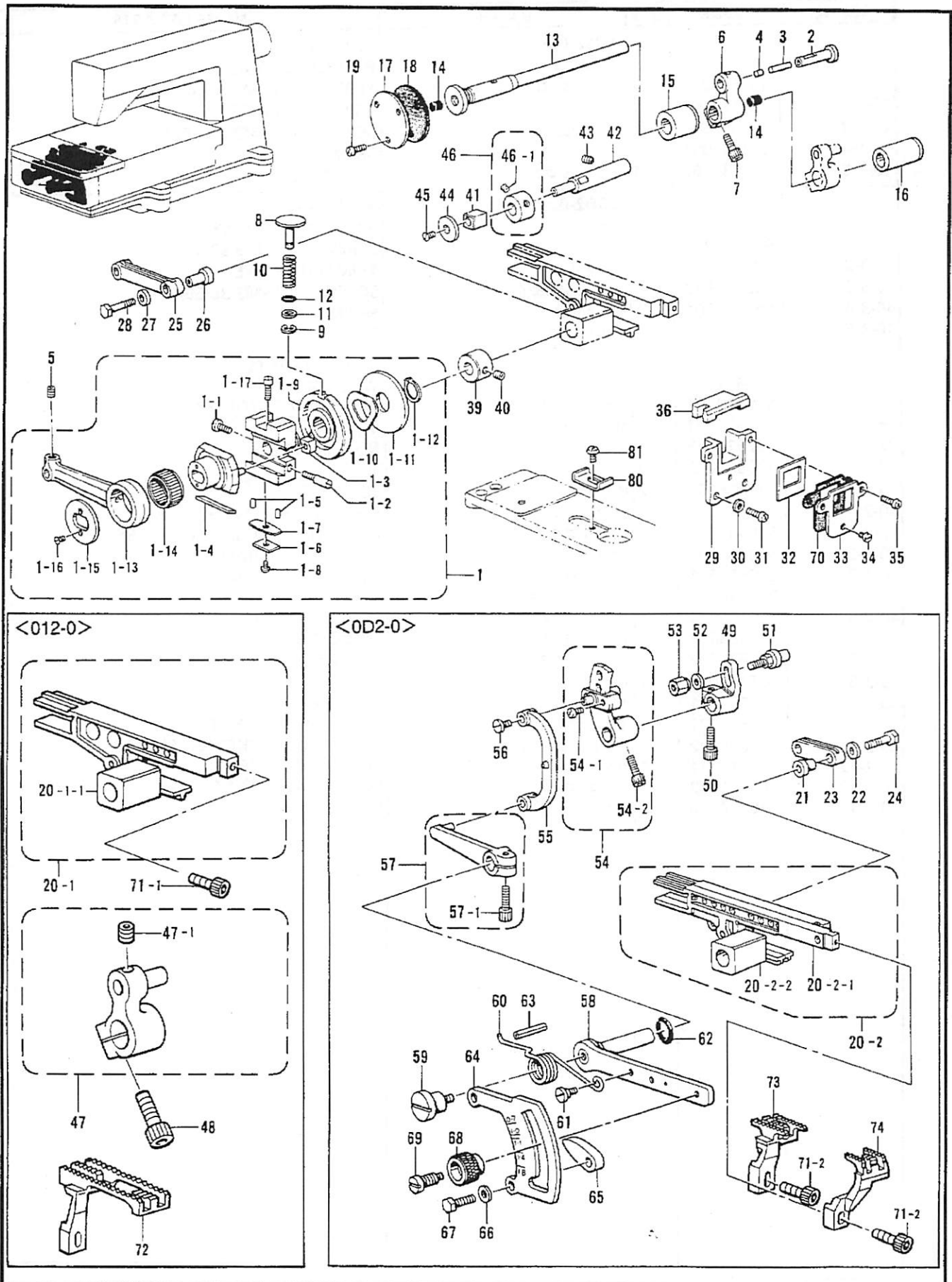

E. 送り関係 / Feed mechanism / Transportvorrichtung / Mécanisme de l'entraînement / Mecanismo de la alimentación

REF.NO.	CODE	Q'TY	ヒンメイ	NAME OF PARTS	RM
1	146528102	1	ヘンシンリンクミ	ECCENTRIC WHEEL ASSY	
1-1	S16498001	1	シメネジ4.37	SCREW, SM4.37	
1-2	145663001	1	トメネジ4.37	SET SCREW, SM4.37	
1-3	140165001	1	チヨウセツピンカワコマ	SLIDE BLOCK	
1-4	146401001	1	ジブ	GIB	
1-5	146402001	2	ジブオサエピン	PIN	
1-6	146403001	1	ジブオサエイタバネS	PLATE SPRING, S	
1-7	146404001	1	ジブオサエイタバネL	PLATE SPRING, L	
1-8	062660512	1	ナベコネジ318-40X5	SCREW, PAN SM3.18-40X5	
1-9	144053001	1	ヘンシンチヨウセツカムクミ	ECCENTRIC WHEEL ADJ. CAM ASSY	
1-10	144055001	1	ナミバネ	SPRING, WAVE	
1-11	146529001	1	ザガネ	WASHER	
1-12	048150143	1	トメワジクヨウC15	RETAINING RING, C15	
1-13	146530001	1	オクリロツド	FEED ROD	
1-14	146531001	1	ニードルジクウケ20	NEEDLE ROLLER BEARING 20	
1-15	140176001	1	オクリロツドオサエイタ	FEED ROD PRESSER PLATE	
1-16	117517003	2	サラネジ2.38	SCREW, FLAT SM2.38	
1-17	100025002	2	シメネジ4.76	SCREW, SM4.76	
2	146532001	1	オクリロツドピン	PIN	
3	147318000	1	ピン	PIN	
4	140326009	1	ゴムセン3.3	RUBBER CAP, 3.3	
5	100251001	1	トメネジ6.35	SET SCREW, SM6.35	
6	146533001	1	オクリウデ	FEED ARM	
7	018771432	1	アナボルト635-40X14	BOLT, SOCKET SM6.35-40X14	
8	S08870001	1	プツシユボタン	PUSH BUTTON	
9	048040342	1	トメワE4	RETAINING RING, E4	
10	S08871001	1	ボタンジクバネ	SPRING	
11	153484001	1	ザガネ4.76	WASHER, PLAIN 4.76	
12	081003670	1	OリングPW3	O RING, PW3	
13	146538101	1	オクリジク	FEED SHAFT	
14	140327001	2	ゴムセン6.3	RUBBER CAP, 6.3	
15	146539000	1	オクリジクメタルL	FEED SHAFT BUSH (L)	
16	146540000	1	オクリジクメタルR	FEED SHAFT BUSH (R)	
17	155144001	1	オクリジクメタルLフタ	FEED SHAFT BUSH (L) CAP	
18	155145000	1	パツキン	PACKING	
19	062670812	3	ナベコ3.57-40X8	SCREW, PAN SM3.57-40X8	
25	146554001	1	サドウオクリリンク	DIFFERENTIAL FEED LINK	
26	146555001	1	サドウオクリリンクブシユ	DIFFERENTIAL FEED LINK BUSH	
27	S23359001	1	ザガネ	WASHER	
28	140217001	1	オクリリンクジクL	FEED LINK SHAFT (L)	
29	155151000	1	オクリダイアンナイ	FEED BAR GUIDE	
30	100645003	2	ザガネ	WASHER	
31	062681012	2	ナベコ437-40X10	SCREW, PAN SM4.37-40X10	
32	155177100	1	ボウジンイタ	FRAGMENT PROTECTOR PLATE	
33	155178001	1	ボウジンイタササエ	FRAGMENT PROTECTOR SUPPORT	
34	S39086001	1	ナベコ357-40X3.5	SCREW, PAN SM3.57-40X3.5	
35	062681012	2	ナベコ437-40X10	SCREW, PAN SM4.37-40X10	
36	S08876000	1	オクリダイボウジンタイ	FEED BAR FRAGMENT PROTECTOR BASE	
39	146741000	1	セツトカラー	SET SCREW COLLAR	
40	101706001	1	トメネジ6.35	SET SCREW, SM6.35	
41	146547000	1	オクリダイカクゴマ	FEED BAR SLIDE BLOCK	
42	146548101	1	オクリダイカクゴマジク	FEED BAR SLIDE BLOCK SHAFT	
43	014780622	1	アナトメネジ6.35クボミ	SET SCREW, SOCKET (CP) SM6.35	
44	S08877001	1	オクリダイカクゴマアテイタ	SLIDE PLATE	
45	107272002	1	サラネジ4.37	SCREW, FLAT M4.37	
46	S03704002	1	セツトカラークミ	SET SCREW COLLAR ASSY	
46-1	014770622	2	アナトメネジ6.35クボミ	SET SCREW, SOCKET (CP) SM6.35	
70	S08467000	1	パツキン	PACKING	
80	S16249001	1	プツシユボタンストツバ	PUSH BUTTON STOPPER	
81	060680512	1	バインド437-40X5	SCREW, BIND SM4.37-40X5	

E. 送り関係 / Feed mechanism / Transportvorrichtung / Mécanisme de l'entraînement / Mecanismo de la alimentación

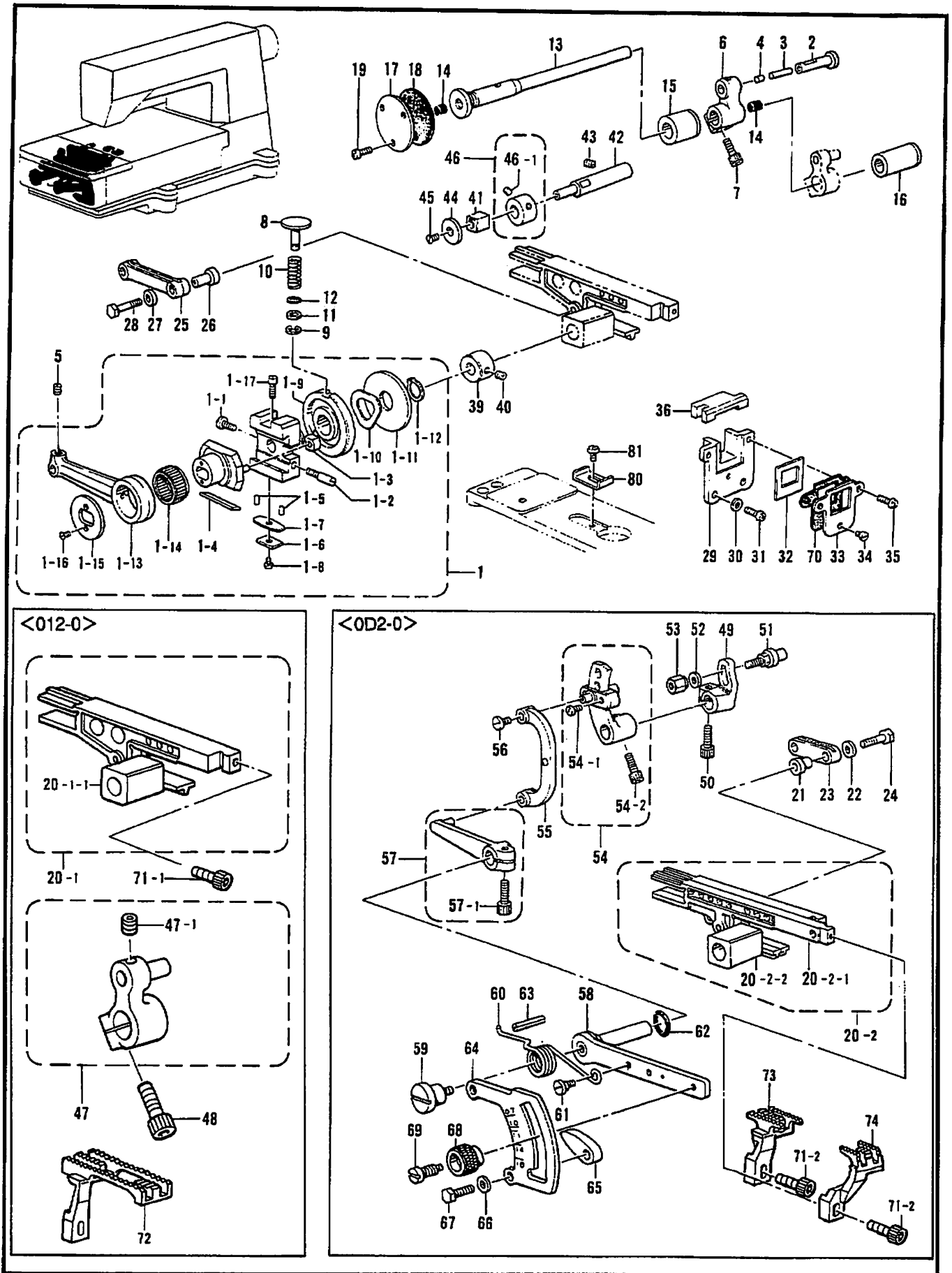

E. 送り関係 / Feed mechanism / Transportvorrichtung / Mécanisme de l'entraînement / Mecanismo de la alimentación

REF.NO.	CODE	Q'TY	ヒンメイ	NAME OF PARTS	RM
			<012-0>	<012-0>	
20-1	S40562001	1	オクリダイカクゴマクミ	FEED BAR SLIDE BLOCK ASSY	
20-1-1	146544000	1	ジヨウゲオクリカクゴマ	FEED LIFTING SLIDE BLOCK	
47	S40559001	1	オクリウデクミ	FEED ARM ASSY	
47-1	014770622	1	アナトメネジ6.35クボミ	SET SCREW, SOCKET (CP) SM6.35	
48	018771432	1	アナボルト635-40X14	BOLT, SOCKET SM6.35-40X14	
71-1	018501022	1	アナボルト5X10	BOLT, SOCKET M5X10	
72	※	1	オクリバ	FEED DOG	
			<0D2-0>	<0D2-0>	
20-2	S08872001	1	オクリダイカクゴマクミ	FEED BAR SLIDE BLOCK ASSY	
20-2-1	S08873001	1	オクリダイクミ	FEED BRACKET ASSY	
20-2-2	146544000	1	ジヨウゲオクリカクゴマ	FEED LIFTING SLIDE BLOCK	
21	140207001	1	シユオクリリンクブシユ	MAIN FEED LINK BUSH	
22	S23359001	1	ザガネ	WASHER	
23	140209001	1	シユオクリリンク	MAIN FEED LINK	
24	140210001	1	シユオクリリンクジクS	MAIN FEED LINK SHAFT (S)	
49	140205001	1	シユオクリウデ	MAIN FEED ARM	
50	018771432	1	アナボルト635-40X14	BOLT, SOCKET SM6.35-40X14	
51	143564001	1	シユオクリジク	MAIN FEED SHAFT	
52	113431002	1	ザガネ	WASHER	
53	143565001	1	ナツト4.76	NUT, SM4.76	
54	S08878001	1	サドウオクリウデクミ	DIFFERENTIAL FEED ARM ASSY	
54-1	062660712	2	ナベコ318-40X7	SCREW, PAN SM3.18-40X7	
54-2	018771432	1	アナボルト635-40X14	BOLT, SOCKET SM6.35-40X14	
55	146556001	1	サドウリンク	DIFFERENTIAL FEED ADJUST LINK	
56	148834001	1	シメネジ3.57	SCREW, M3.57	
57	S08879001	1	リンクレバーネジツキ	DIFFERENTIAL FEED LINK LEVER ASSY	
57-1	018771432	1	アナボルト635-40X14	BOLT, SOCKET SM6.35-40X14	
58	S08880001	1	サドウチヨウセツレバー	DIFFERENTIAL FEED ADJUST LEVER	
59	146559001	1	ダンネジ5.56	STUD SCREW, M5.56	
60	146560101	1	レバーバネ	LEVER SPRING	
61	100294002	1	ダンネジ4.76	SHOULDER SCREW, SM4.76	
62	109203001	1	リング	O RING	
63	047502242	1	スプリングピンAW5	PIN, SPRING ROLL AW5	
64	S08881101	1	サドウリヨウメモリアタ	DIFFERENTIAL STITCH CONTROL	
65	146563001	2	チヨウセツレバーストツバ	STOPPER FOR DIFFERENTIAL STITCH CONTROL	
66	025770232	2	ヒラザガネチユウ6.35	WASHER, PLAIN M 6.35	
67	017781412	2	ボルト6.35X14	BOLT, SM6.35X14	
68	155175001	1	セツトネジツマミ	SET SCREW KNOB	
69	155176001	1	セツトネジ	SET SCREW	
71-2	154965001	2	アナボルト3.57X8	BOLT, SOCKET SM3.57X8	
73	※	1	シユオクリバ	MAIN FEED DOG	
74	※	1	サドウオクリバ	DIFFERENTIAL FEED DOG	

H. 下軸関係 / Lower shaft mechanism / Untere Welle / Mécanisme de l'arbre inférieur / Mecanismo del eje inferior

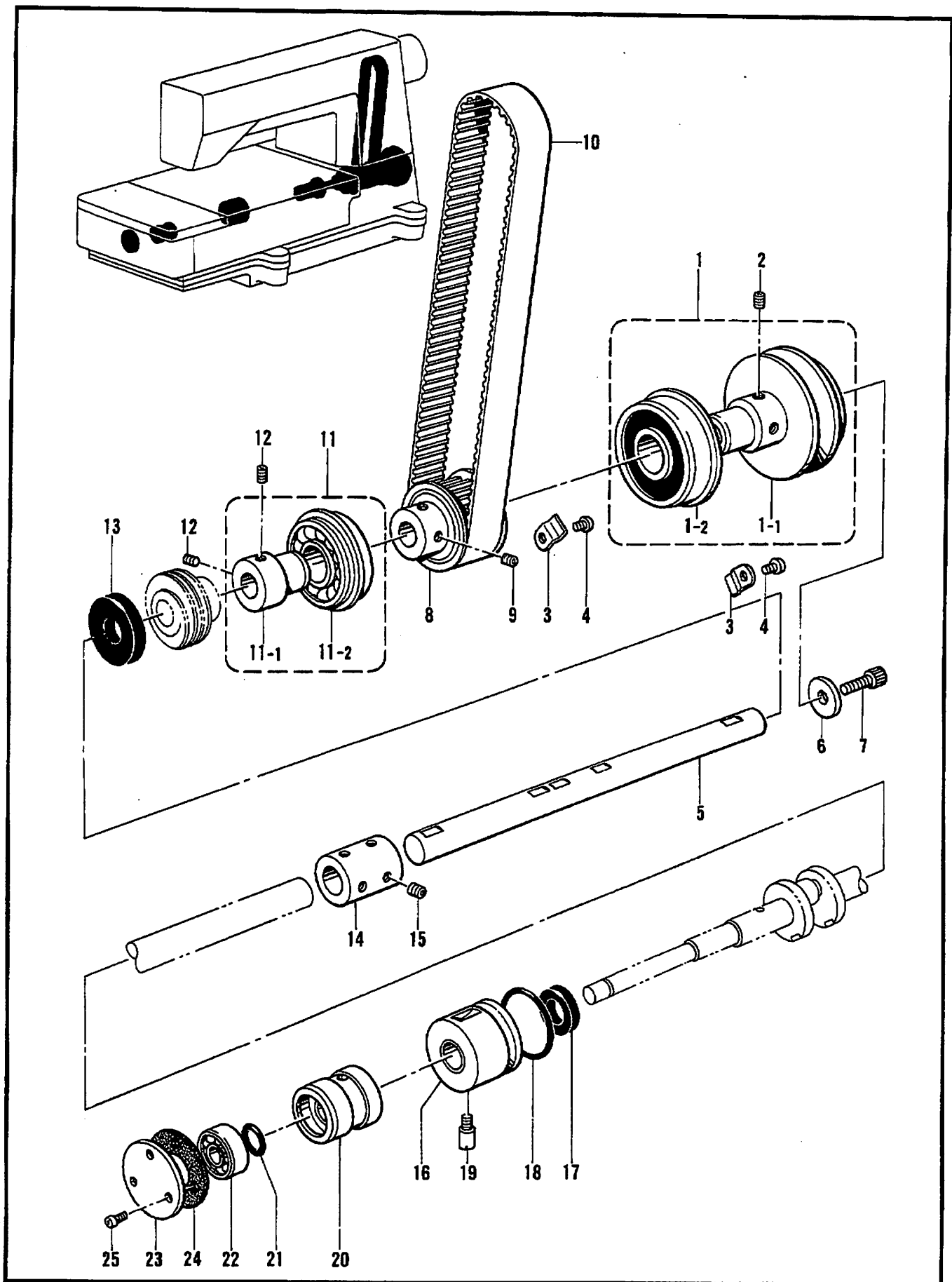

118-266-305

H. 下軸関係 / Lower shaft mechanism / Untere Welle / Mécanisme de l'arbre inférieur / Mecanismo del eje inferior

REF.NO.	CODE	Q'TY	ヒンメイ	NAME OF PARTS	RM
1	S08889101	1	Vベルトプーリクミ	V-BELT PULLEY ASSY	
1-1	S08890001	1	Vベルトプーリ	V-BELT PULLEY	
1-2	S14622001	1	タマジクウケ6304VV	BALL BEARING, 6304VV	
2	014780622	2	アナトメネジ6.35クボミ	SET SCREW, SOCKET (CP) SM6.35	
3	153734001	2	アームササエイタバネ	PLATE SPRING	
4	062680612	2	ナベコ4.37-40X6	SCREW, PAN SM4.37-40X6	
5	S08891001	1	シタジクR	LOWER SHAFT (R)	
6	154886001	1	ザガネ	WASHER	
7	018771432	1	アナボルト635-40X14	BOLT, SOCKET SM6.35-40X14	
8	S08892001	1	タイミングプーリDクミ	TIMING PULLEY (D) ASSY	
9	014770622	2	アナトメネジ6.35クボミ	SET SCREW, SOCKET (CP) SM6.35	
10	S08895002	1	タイミングベルト	TIMING BELT	
11	S08896101	1	タマジクウケクミ	BALL BEARING ASSY	
11-1	S08897001	1	タマジクウケブシユ	BALL BEARING BUSH	
11-2	S14623001	1	タマジクウケ6204DV	BALL BEARING, 6204DV	
12	014770622	2	アナトメネジ6.35クボミ	SET SCREW, SOCKET (CP) SM6.35	
13	S08898000	1	オイルシール	OIL SEAL	
14	S08899001	1	ジクツギテ	SHAFT JOINT	
15	014770622	4	アナトメネジ6.35クボミ	SET SCREW, SOCKET (CP) SM6.35	
16	S08900000	1	クランクジクメタルRクミ	LOWER SHAFT BUSH (R) ASSY	
17	S08903000	1	ダストシール	DUST SEAL	
18	081032870	1	OリングS32	O RING, S32	
19	S08967001	1	シメネジ4.76	SCREW, SM4.76	
20	S08904000	1	クランクジクメタルLクミ	CRANK SHAFT BUSH (L) ASSY	
21	114294001	1	Oリング	O RING	
22	072600000	1	タマジクウケ6000	BALL BEARING, 6000	
23	143311001	1	ベアリングフタ	BEARING COVER	
24	143312000	1	ベアリングフタバツキン	BEARING COVER PACKING	
25	062670812	3	ナベコ3.57-40X8	SCREW, PAN SM3.57-40X8	

J. ルーパー関係 / Looper mechanism / Greifer / Mécanisme des griffes / Mecanismo del presilladora

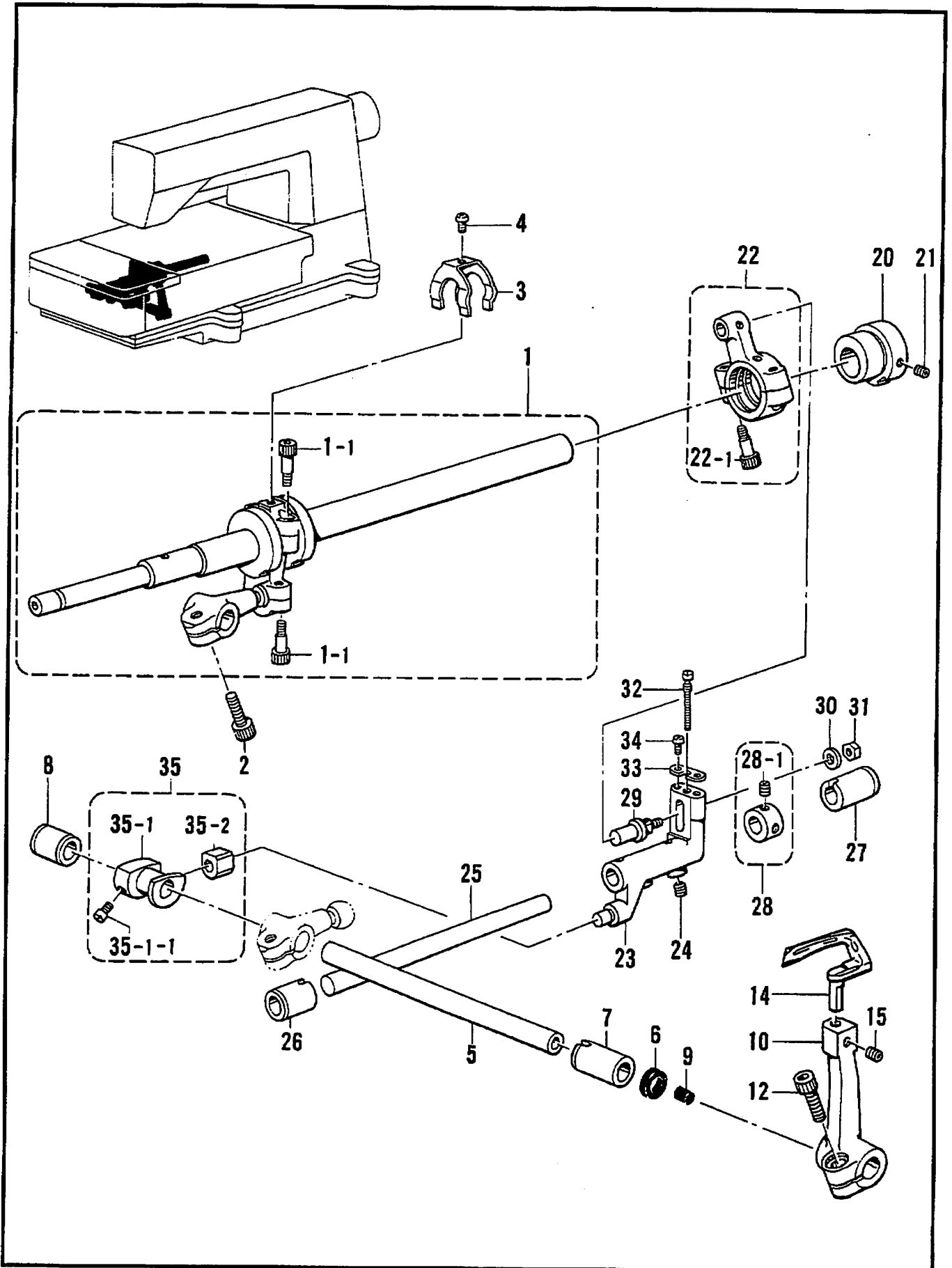

118-266-306

J. ルーパ-関係 / Looper mechanism / Greifer / Mécanisme des griffes / Mecanismo del presilladora

REF.NO.	CODE	Q'TY	ヒンメイ	NAME OF PARTS	RM
1	S40567001	1	ルーバクランクジククミ	LOOPER CRANK SHAFT	
1-1	148425001	4	アナボルト4.37X14	BOLT, SOCKET SM4.37X14	
2	018771432	1	アナボルト635-40X14	BOLT, SOCKET SM6.35-40X14	
3	110704001	1	ウフル-バロツドフレドメ	LOOPER CONNECTING ROD STOPPER	
4	062660412	1	ナベコ318-40X4	SCREW, PAN SM3.18-40X4	
5	S40977001	1	ルーバジク	LOOPER SHAFT	
6	155539000	1	ダストシール	DUST SEAL	
7	S08770000	1	ジクメタル	SHAFT BUSH	
8	S08911000	1	ルーバジクメタルB	LOOPER SHAFT BUSHING (B)	
9	140327001	1	ゴムセン6.3	RUBBER CAP, 6.3	
10	S08912001	1	ルーバホルダ	LOOPER HOLDER	
12	018771432	1	アナボルト635-40X14	BOLT, SOCKET SM6.35-40X14	
14	S40569001	1	ルーバ	LOOPER	
15	014680422	1	アナトメネジ4.37クボミ	SET SCREW, SOCKET (CP) SM4.37	
20	S08914001	1	ゼンゴヘンシンリン	LONGITUDINAL ECCENTRIC CAM	
21	014680622	2	アナトメネジ4.37クボミ	SET SCREW, SOCKET (CP) SM4.37	
22	146624101	1	ゼンゴロツドクミ	LONGITUDINAL FEED ROD ASSY	
22-1	148425001	2	アナボルト4.37X14	BOLT, SOCKET SM4.37X14	
23	S08915001	1	ゼンゴレバー	LONGITUDINAL LEVER	
24	014770622	2	アナトメネジ6.35クボミ	SET SCREW, SOCKET (CP) SM6.35	
25	S08916001	1	ゼンゴレバージク	LONGITUDINAL FEED SHAFT	
26	S08917000	1	レバージクメタルL	LONGITUDINAL FEED SHAFT BUSH (L)	
27	S08754000	1	ハリウケBジクメタルR	KNIFE DRIVING SHAFT BUSH (R)	
28	S03704002	1	セツトカラークミ	SET SCREW COLLAR ASSY	
28-1	014770622	2	アナトメネジ6.35クボミ	SET SCREW, SOCKET (CP) SM6.35	
29	S08918001	1	ゼンゴロツドピン	PIN	
30	148847001	1	ザガネ	WASHER, PLAIN 4.76	
31	110161006	1	ナツト4.76	NUT, SM4.76	
32	S08919001	1	ヘンシンチヨウセツネジ	ADJUST SCREW	
33	S08920001	1	ヘンシントメイタ	ECCENTRIC WHEEL STOPPER PLATE	
34	062630612	2	ナベコ238-56X6	SCREW, PAN SM2.38-56X6	
35	S08921101	1	ゼンゴコマクミ	LONGITUDINAL BLOCK ASSY	
35-1	S09251001	1	ゼンゴコマネジツキ	LONGITUDINAL BLOCK WITH SCREW	
35-1-1	120990001	2	アタマツキトメネジ4.37	SET SCREW, SM4.37	
35-2	140313001	1	ゼンゴレバーカクゴマ	LONGITUDINAL FEED LEVER SLIDE BLOCK	

K. 給油潤滑關係 / Lubrication / Schmierung / Lubrification / Lubricación

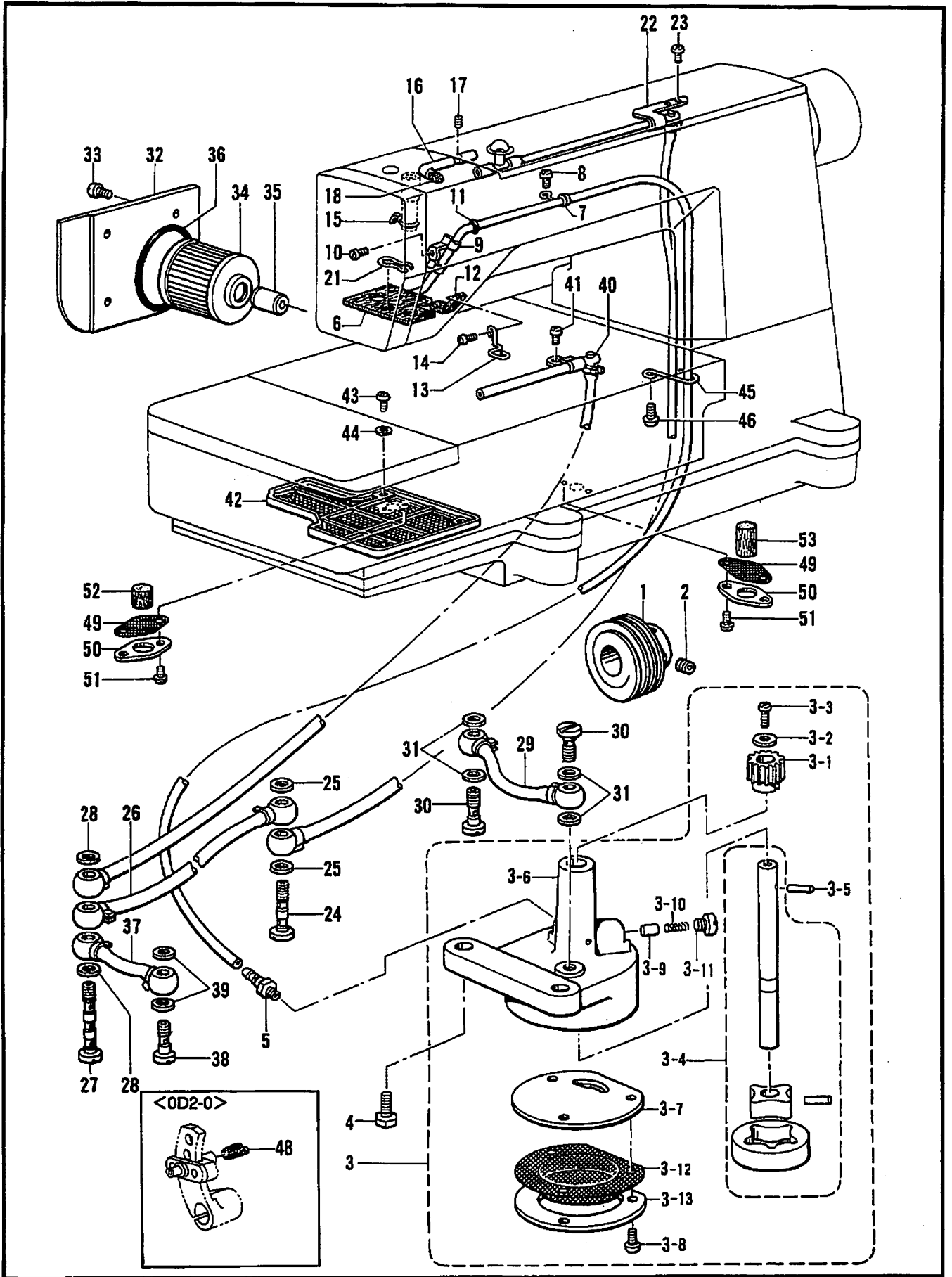

K. 給油潤滑関係 / Lubrication / Schmierung / Lubrification / Lubricación

REF.NO.	CODE	Q'TY	ヒンメイ	NAME OF PARTS	RM
1	S08935001	1	ウオーム	WORM	
2	014770622	2	アナトメネジ6.35クボミ	SET SCREW, SOCKET (CP) SM6.35	
3	S08936201	1	トロコイドポンプクミ	PUMP ASSY	
3-1	144619000	1	ウオームホイール	WORM WHEEL	
3-2	025350332	1	ヒラザガネダイ3.5	WASHER, PLAIN L 3.5	
3-3	062670812	1	ナベコ3.57-40X8	SCREW, PAN SM3.57-40X8	
3-4	S08937101	1	ポンプロータークミ	PUMP INNER ROTER ASSY	
3-5	144622001	1	ミゾツキピンEガタ	DOWEL PIN (E)	
3-6	S08939100	1	ポンプケース	PUMP CASE	
3-7	147527000	1	ポンプフタ	PUMP COVER	
3-8	062671012	3	ナベコ357-40X10	SCREW, PAN SM3.57-40X10	
3-9	144875001	1	プランジャー	PLUNGER	
3-10	144876001	1	プランジャーバネ	SPRING	
3-11	112467002	1	シメネジ6.35	SCREW, SM6.35	
3-12	147528100	1	ロカモウ	OIL FILTER	
3-13	147529000	1	ロカモウオサエ	OIL FILTER FLANGE	
4	017781412	2	ボルト6.35X14	BOLT, SM6.35X14	
5	142359001	1	オイルクチ	OIL FEEDING PIPE	
6	S08940000	1	チューブクミ	OIL TUBE ASSY	
7	112743001	1	クミヒモササエ	WICK SUPPORT	
8	062670612	1	ナベコ357-40X6	SCREW, PAN SM3.57-40X6	
9	151429001	1	チューブホルダ	TUBE HOLDER	
10	062670612	1	ナベコ357-40X6	SCREW, PAN SM3.57-40X6	
11	118770001	1	パツキン	PACKING	
12	S08943000	1	カクゴマフエルト	FELT	
13	S08944001	1	フェルトオサエ	FELT SUPPORT	
14	062670612	1	ナベコ357-40X6	SCREW, PAN SM3.57-40X6	
15	157840000	1	クミヒモ3X3	WICK, 3X3 (L = 100)	
16	S08945001	1	オイルパイプ	OIL PIPE	
17	014680622	1	アナトメネジ4.37クボミ	SET SCREW, SOCKET (CP) SM4.37	
18	S08946000	1	フェルト	FELT	
21	145737001	1	フェルトオサエ	FELT SUPPORT	
22	S08948001	1	ロツドオイルパイプUクミ	MAIN OIL PIPE (U) ASSY	
23	062670612	2	ナベコ357-40X6	SCREW, PAN SM3.57-40X6	
24	112364001	1	ハイユパイプツギテネジ	OIL FEEDING PIPE JOINT SCREW	
25	159476000	2	ザガネ	WASHER	
26	S08951001	1	ビニルチューブクミ	OIL TUBE ASSY	
27	112351001	1	ハイユパイプネジ	OIL FEEDING PIPE SCREW	
28	159476000	2	ザガネ	WASHER	
29	155282101	1	ビニルチューブクミ	OIL TUBE ASSY	
30	112359002	2	ハイユパイプツギテネジ	SCREW	
31	159476000	4	ザガネ	WASHER	
32	S08955051	1	オイルフィルターフタ	OIL FILTER CAP	
33	062680812	4	ナベコ437-40X8	SCREW, PAN SM4.37-40X8	
34	S08956100	1	オイルフィルター	OIL FILTER	
35	S08957001	1	オイルクチ	OIL FEEDING PIPE	
36	081044070	1	リングP44	O RING, P44	
37	S08953001	1	ビニルチューブクミ	OIL TUBE ASSMBLY	
38	112359002	1	ハイユパイプツギテネジ	SCREW	
39	159476000	2	ザガネ	WASHER	
40	S08958001	1	ロツドオイルパイプDクミ	MAIN OIL PIPE (D) ASSY	
41	062670612	1	ナベコ357-40X6	SCREW, PAN SM3.57-40X6	
42	S09316000	1	オイルフィルターD	OIL FILTE (D)	
43	062680812	4	ナベコ437-40X8	SCREW, PAN SM4.37-40X8	
44	100645003	4	ザガネ	WASHER	
45	S09125001	1	チューブガイド	OIL TUBE GUIDE	
46	062780812	1	ナベコ635-28X8	SCREW, PAN SM6.35-28X8	
49	155294100	2	ロカモウ	OIL FILTER	
50	155295001	2	ロカモウオサエイタ	OIL FILTER FLANGE	

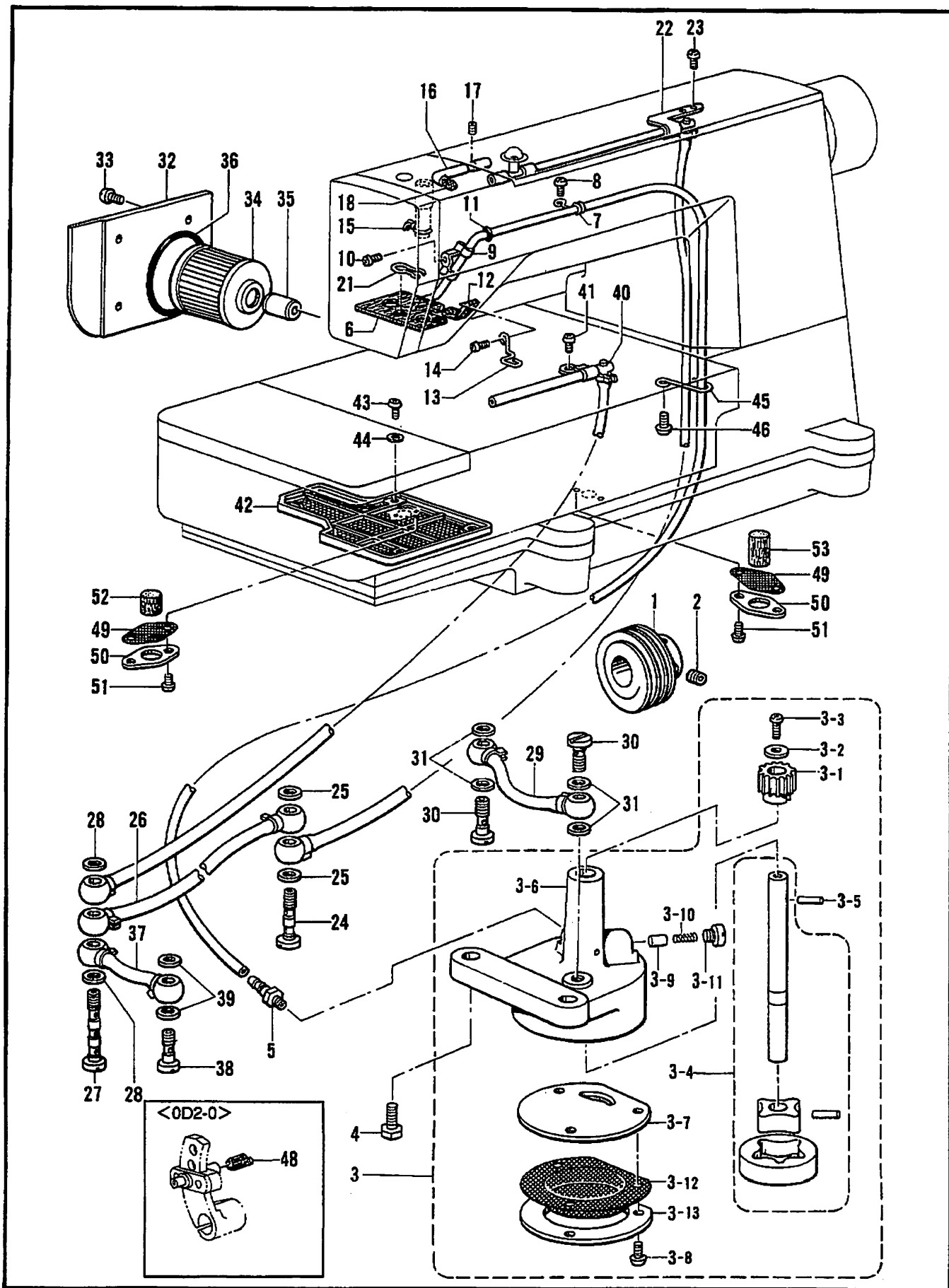

K. 給油潤滑関係 / Lubrication / Schmierung / Lubrification / Lubricación

REF.NO.	CODE	Q'TY	ヒンメイ	NAME OF PARTS	RM
51	062670612	4	ナベコ357-40X6	SCREW, PAN SM3.57-40X6	
52	151927001	1	クラッチフェルト	CLUTCH FELT	
53	112754001	1	フェルト	FELT	
48	147363000	1	<0D2-0> フェルト	<0D2-0> FELT	

118-266-350

L. 糸払い関係 / Thread wiper mechanism / Fadenwischvorrichtung / Mécanisme de tire-fil / Mecanismo del limpiador de hilo

<オプションパーツ / OPTION PARTS>

電磁式

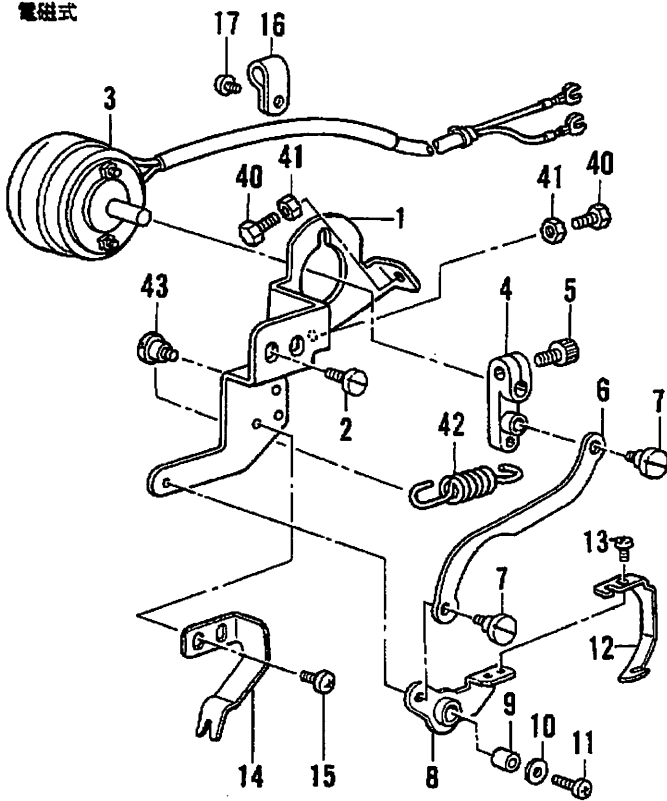

エア式

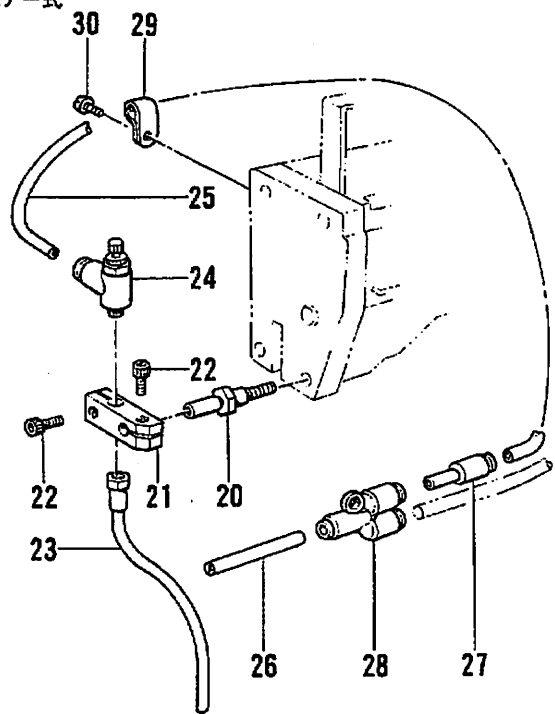

L. 糸払い関係 / Thread wiper mechanism / Fadenwischvorrichtung / Mécanisme de tire-fil / Mecanismo del limpiador de hilo

REF.NO.	CODE	Q'TY	ヒンメイ	NAME OF PARTS	RM
			"オプションパーツ" <電磁式>	"OPTION PARTS" <SOLENOID TYPE>	
1	S44908001	1	イトハライドダイ	THREAD WIPER BRACKET	
2	100644005	2	シメネジ4.37	SCREW, SM4.37	
3	S21869101	1	イトハラソレノイド	THREAD WIPER SOLENOID	
4	S44909001	1	イトハライレバー	THREAD WIPER LEVER	
5	018681022	1	アナボルト4.37X10	BOLT, SOCKET SM4.37X10	
6	S21872101	1	イトハライロツド	THREAD WIPER ROD	
7	105237002	2	ダンネジ3.57	SHOULDER SCREW, SM3.57	
8	S21873001	1	イトハライクランク	THREAD WIPER CRANK	
9	S21874000	1	シテンジク	FULCRUM SHAFT	
10	S21875001	1	ザガネ	WASHER	
11	062670812	1	ナベコ3.57-40X8	SCREW, PAN SM3.57-40X8	
12	S44910001	1	イトハライ	THREAD WIPER	
13	062630412	2	ナベコ238-56X4	SCREW, PAN SM2.38-56X4	
14	S21877001	1	イトツカミバネ	THREAD CLAMP SPRING	
15	060670512	2	バインド357-40X5	SCREW, BIND SM3.57-40X5	
16	149547000	5	コードオサエ	CORD HOLDER, 4N	
17	062680712	5	ナベコ437-40X7	SCREW, PAN SM4.37-40X7	
40	017711412	2	ボルト4.76X14	BOLT, SM4.76X14	
41	110161006	2	ナツト4.76	NUT, SM4.76	
42	S21988001	1	モドシバネ	RETURN SPRING	
43	105237002	1	ダンネジ3.57	SHOULDER SCREW, SM3.57	
			<エア-式>	<AIR TYPE>	
20	S28897001	1	ワイバードダイジク	WIPER BRACKET SHAFT	
21	S28898001	1	ワイバードダイ	WIPER BRACKET	
22	018681022	2	アナボルト4.37X10	BOLT, SOCKET SM4.37X10	
23	S28899001	1	ワイバークミ	WIPER ASSY	
24	S23660000	1	スピードコントローラ	SPEED CONTROLLER	
25	S14085011	1	エアチューブ	AIR TUBE, 4X1410	
26	S28744000	1	エアチューブ	AIR TUBE (L = 40)	
27	S28902000	1	レジュ-サ04-06	REDUCER 04-06	
28	S24021000	1	ユニオンワイ6	UNION 6	
29	S10243000	5	ナイロンクランプNK-3N	CORD HOLDER, NK-3N	
30	062680712	5	ナベコ437-40X7	SCREW, PAN SM4.37-40X7	
糸払いセット/THREAD WIPER SET			電磁式/SOLENOID TYPE	エア-式/AIR TYPE	
			S44920-001	S28896-001	

M. 糸調子関係 / Thread tension / Fadenspannung / Tension du fil / Tensión del hilo

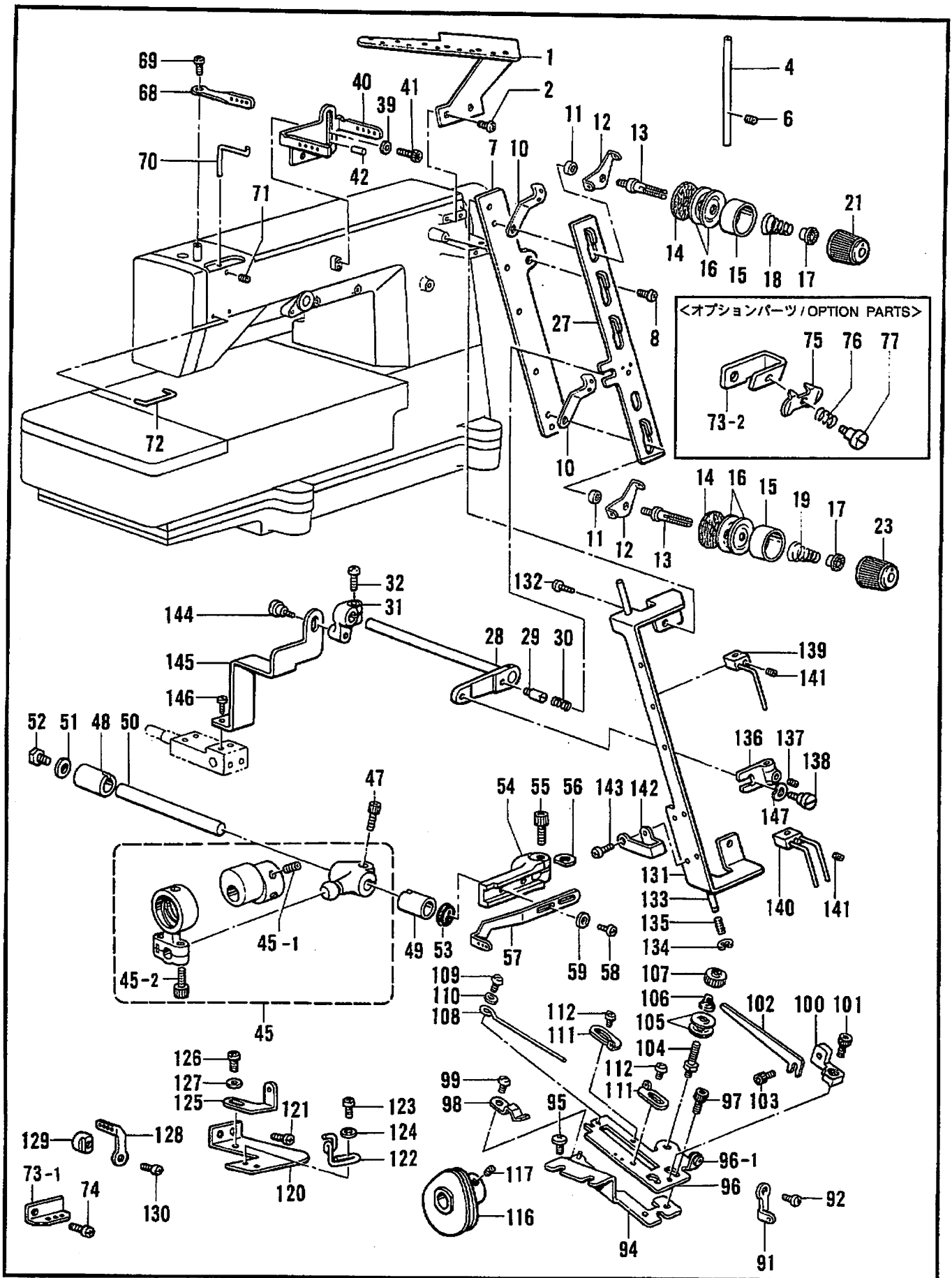

118-266-418

M. 糸調子関係 / Thread tension / Faderspannung / Tension du fil / Tensión del hilo

REF.NO.	CODE	Q'TY	ヒンメイ	NAME OF PARTS	RM
1	S08961101	1	シュイトアンナイ	MAIN THREAD GUIDE	
2	062680812	2	ナベコ437-40X8	SCREW, PAN SM4.37-40X8	
4	150645009	1	イトアンナイパイプL	THREAD GUIDE PIPE, L	
6	014680422	1	アナトメネジ4.37クボミ	SET SCREW, SOCKET (CP) SM4.37	
7	S08962109	1	イトチヨウシダイ	TENSION BRACKET	
8	062681012	2	ナベコ437-40X10	SCREW, PAN SM4.37-40X10	
10	S08963001	2	イトチヨウシダイイトアンナイ	TENSION BRACKET THREAD GUIDE	
11	S08964001	2	カンザ	SPACER	
12	110813001	2	ハリイトアンナイ	NEEDLE THREAD GUIDE	
13	159574101	2	イトチヨウシボウ	TENSION STUD	
14	110832009	2	イトチヨウシサラフェルト	TENSION DISC FELT	
15	144103009	2	イトチヨウシサラオサエ	TENSION DISC PRESSER	
16	145446001	4	イトチヨウシサラ	TENSION DISC	
17	S30564000	2	チヨウシバネウエザガネ	TENSION SPRING WASHER	
18	144104001	1	ハリイトチヨウシバネ	THREAD TENSION ADJUST SPRING	
19	144110001	1	シタルーバイトチヨウシバネ	THREAD TENSION ADJUST SPRING	
21	S30565003	1	イトチヨウシナツト	TENSION NUT, RED	
23	S30565003	1	イトチヨウシナツト	TENSION NUT, RED	
27	S21879001	1	イトユルメイタ	TENSION RELEASE PLATE	
28	S21880001	1	イトユルメジク	TENSION RELEASE SHAFT	
29	S21881001	1	シメネジ4.76	SCREW, M4.76	
30	S21882001	1	イトユルメイタオシバネ	SPRING	
31	S21883001	1	イトユルメウデ	TENSION RELEASE ARM	
32	062681212	1	ナベコ437-40X12	SCREW, PAN SM4.37-40X12	
39	100645003	1	ザガネ	WASHER	
40	S08969201	1	チユウカンイトアンナイ	THREAD GUIDE	
41	018680822	1	アナボルト4.37X8	BOLT, SOCKET SM4.37X8	
42	143602001	1	ミゾツキピン	DOWEL PIN	
45	S08971201	1	ハリイトクリヘンシンリンクミ	NEEDLE THREAD TAKE-UP ECCENTRIC ASSY	
45-1	014770622	2	アナトメネジ6.35クボミ	SET SCREW, SOCKET (CP) SM6.35	
45-2	018401422	2	アナボルト4X14	BOLT, SOCKET M4X14	
47	018771432	1	アナボルト635-40X14	BOLT, SOCKET SM6.35-40X14	
48	155220000	1	ホジヨアツメタルR	AUTO PRESSER ARM BUSH (R)	
49	S08770000	1	ジクメタル	SHAFT BUSH	
50	S08976001	1	ハリイトクリジク	NEEDLE THREAD TAKE-UP SHAFT	
51	S00356001	1	ザガネ	WASHER	
52	S00383001	1	ボルト5.56X8	BOLT, M5.56X8	
53	155539000	1	ダストシール	DUST SEAL	
54	S08977001	1	ハリイトクリレバー	NEEDLE THREAD TAKE-UP LEVER	
55	018771432	1	アナボルト635-40X14	BOLT, SOCKET SM6.35-40X14	
56	155162001	1	スパーサ	SPACER	
57	S08978001	1	ハリイトクリ	NEEDLE THREAD TAKE-UP	
58	062681012	2	ナベコ437-40X10	SCREW, PAN SM4.37-40X10	
59	100645003	2	ザガネ	WASHER	
68	S08981001	1	ハリボウテンピン	NEEDLE BAR TAKE-UP	
69	062670612	1	ナベコ357-40X6	SCREW, PAN SM3.57-40X6	
70	S08982001	1	ハリイトウケ	NEEDLE THREAD GUIDE	
71	014680422	1	アナトメネジ4.37クボミ	SET SCREW, SOCKET (CP) SM4.37	
72	S08983001	1	アームハリイトウケ	ARM NEEDLE THREAD GUIDE	
73-1	S28438001	1	アームイトアンナイD	ARM THREAD GUIDE (D)	
74	062680812	1	ナベコ437-40X8	SCREW, PAN SM4.37-40X8	
91	S08970001	1	イトアンナイS	THREAD GUIDE, S	
92	062680612	1	ナベコ4.37-40X6	SCREW, PAN SM4.37-40X6	
94	S18530001	1	テンビンドダイDクミ	LOOPER THREAD TAKE-UP BASE (D) ASSY	
95	060680712	2	バインド437-40X7	SCREW, BIND SM4.37-40X7	
96	S18532001	1	テンビンドダイUクミ	LOOPER THREAD TAKE-UP BASE (U) ASSY	
96-1	146924000	1	スレツドブツシユ	THREAD BUSH	
97	018680822	2	アナボルト4.37X8	BOLT, SOCKET SM4.37X8	
98	S18534001	1	ドダイオサエバネ	SPRING	

M. 糸調子関係 / Thread tension / Faderspannung / Tension du fil / Tension del hilo

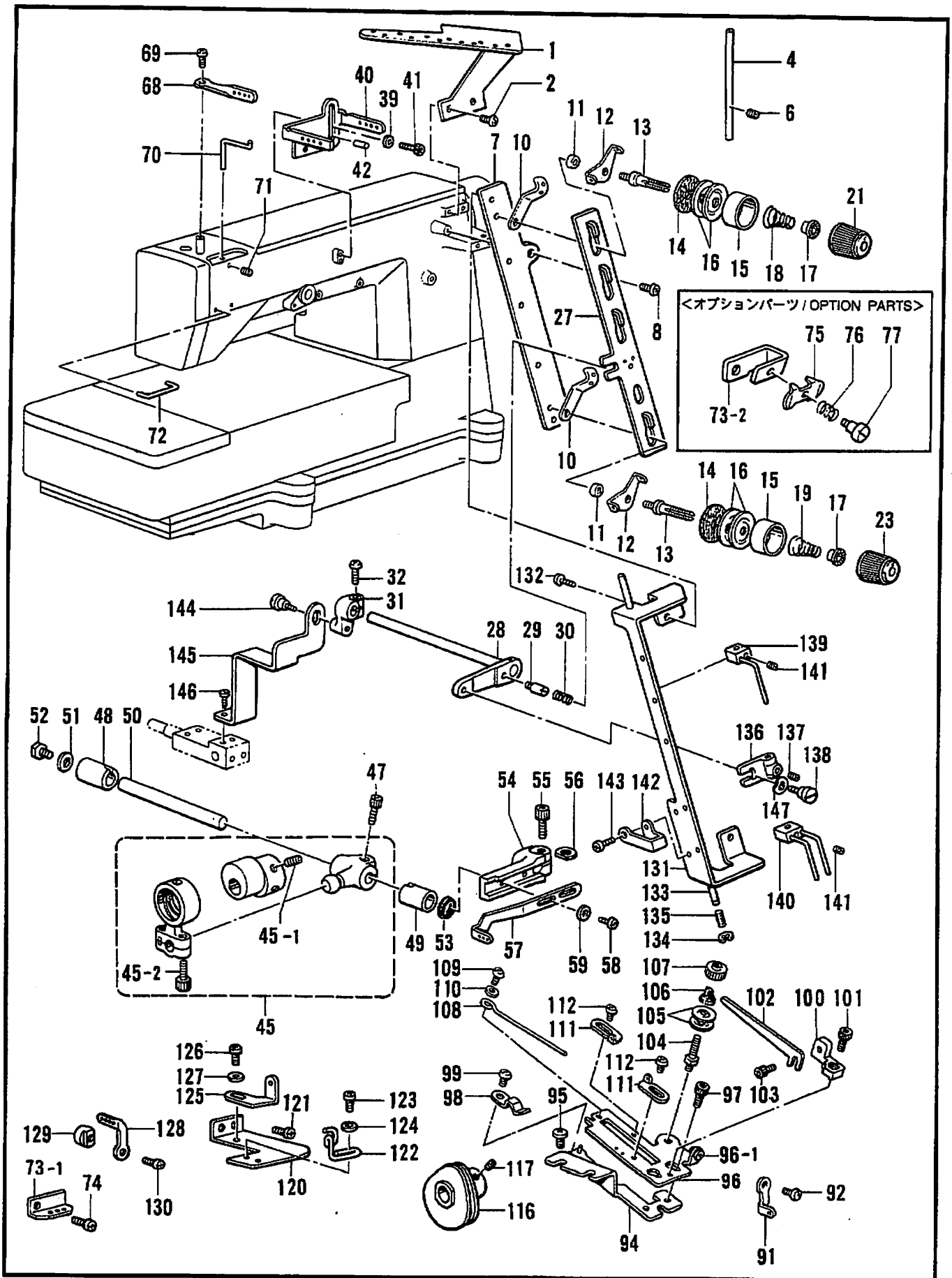

118-266-418

M. 糸調子関係 / Thread tension / Fadernspannung / Tension du fil / Tensión del hilo

REF.NO.	CODE	Q'TY	ヒンメイ	NAME OF PARTS	RM
99	062670512	1	ナベコ357-40X5	SCREW, PAN SM3.57-40X5	
100	S18535001	1	イトオサエドダイ	THREAD PRESSER BASE	
101	154965001	1	アナボルト3.57X8	BOLT, SOCKET SM3.57X8	
102	S08992001	1	テンビンイトオサエ	LOOPER TAKE-UP PRESSER	
103	154965001	1	アナボルト3.57X8	BOLT, SOCKET SM3.57X8	
104	S08987001	1	イトチヨウシボウ	THREAD TENSION CONTROL STUD	
105	144504001	2	イトアンナイサラ	THREAD GUIDE DISC	
106	144505000	1	イトアンナイバネ	SPRING	
107	155510001	1	イトチヨウシナツト	TENSION NUT	
108	S08993101	1	テンビンイトウケ	TAKE-UP THREAD GUIDE	
109	062670512	1	ナベコ357-40X5	SCREW, PAN SM3.57-40X5	
110	105161004	1	ザガネ	WASHER	
111	S08994001	2	テンビンイトアンナイ	THREAD GUIDE	
112	060660416	2	バインド318-40X4	SCREW, BIND SM3.18-40X4	
116	S40572001	1	シタイトテンビンクミ	LOOPER THREAD TAKE-UP ASSY	
117	014680422	2	アナトメネジ4.37クボミ	SET SCREW, SOCKET (CP) SM4.37	
120	S40570001	1	イトアンナイドダイ	THREAD GUIDE BRACKET	
121	060670812	2	バインド357-40X8	SCREW, BIND SM3.57-40X8	
122	S40571001	1	シタイトアンナイF	LOWER THREAD GUIDE (F)	
123	062670612	1	ナベコ357-40X6	SCREW, PAN SM3.57-40X6	
124	105161004	1	ザガネ	WASHER	
125	155313001	1	ウフルーバイトアンナイ	LOOPER THREAD GUIDE	
126	062670512	1	ナベコ357-40X5	SCREW, PAN SM3.57-40X5	
127	105161004	1	ザガネ	WASHER	
128	S12882001	1	イトアンナイ	THREAD GUIDE	
129	S25818001	1	チヨウセツレバーストツバ	STOPPER FOR ADJUST LEVER	
130	062350612	1	ナベコM3.5X6	SCREW, PAN M3.5X6	
131	S21884001	1	イトユルメアンナイ	TENSION RELEASE GUIDE	
132	060680512	2	バインド437-40X5	SCREW, BIND SM4.37-40X5	
133	S21885001	1	イトトリジク	THREAD TAKE-UP SHAFT	
134	048030342	1	トメワE3	RETAINING RING, E3	
135	S21886001	1	カンシヨウバネ	SHOCK ABSORBING SPRING	
136	S21887001	1	イトトリレバー	THREAD TAKE-UP LEVER	
137	014680422	1	アナトメネジ4.37クボミ	SET SCREW, SOCKET (CP) SM4.37	
138	144526001	1	ダンネジ4.37	SHOULDER SCREW, SM4.37	
139	S21888001	1	イトトリプロツクSクミ	THREAD TAKE-UP BLOCK (S) ASSY	
140	S21891001	1	イトトリプロツクWクミ	THREAD TAKE-UP BLOCK (W) ASSY	
141	014680422	2	アナトメネジ4.37クボミ	SET SCREW, SOCKET (CP) SM4.37	
142	S21893001	1	イトユルメイトミチ	THREAD HANDING AREA	
143	062670512	1	ナベコ357-40X5	SCREW, PAN SM3.57-40X5	
144	144526001	1	ダンネジ4.37	SHOULDER SCREW, SM4.37	
145	S21894001	1	イトユルメクドウイタ	TENSION RELEASE DRIVING PLATE	
146	100644005	2	シメネジ4.37	SCREW, SM4.37	
147	103810002	1	ナミガタバネザガネ	WASHER, WAVE SPRING	
73-2	S08984001	1	サブテンションドダイ	SUB TENSION BASE	
75	112300001	1	ハリイトオサエ	NEEDLE THREAD CLAMP	
76	112299001	1	ハリイトアンナイオシバネ	COIL SPRING	
77	112301001	1	ダンネジ3.18	SHOULDER SCREW, M3.18	

N. 下飾り糸切り関係 / Lower thread trimmer mechanism / Unterefadensabschneider /
 Mécanisme de coupe-fils inférieur / Dispositivo de cortahilos inferior

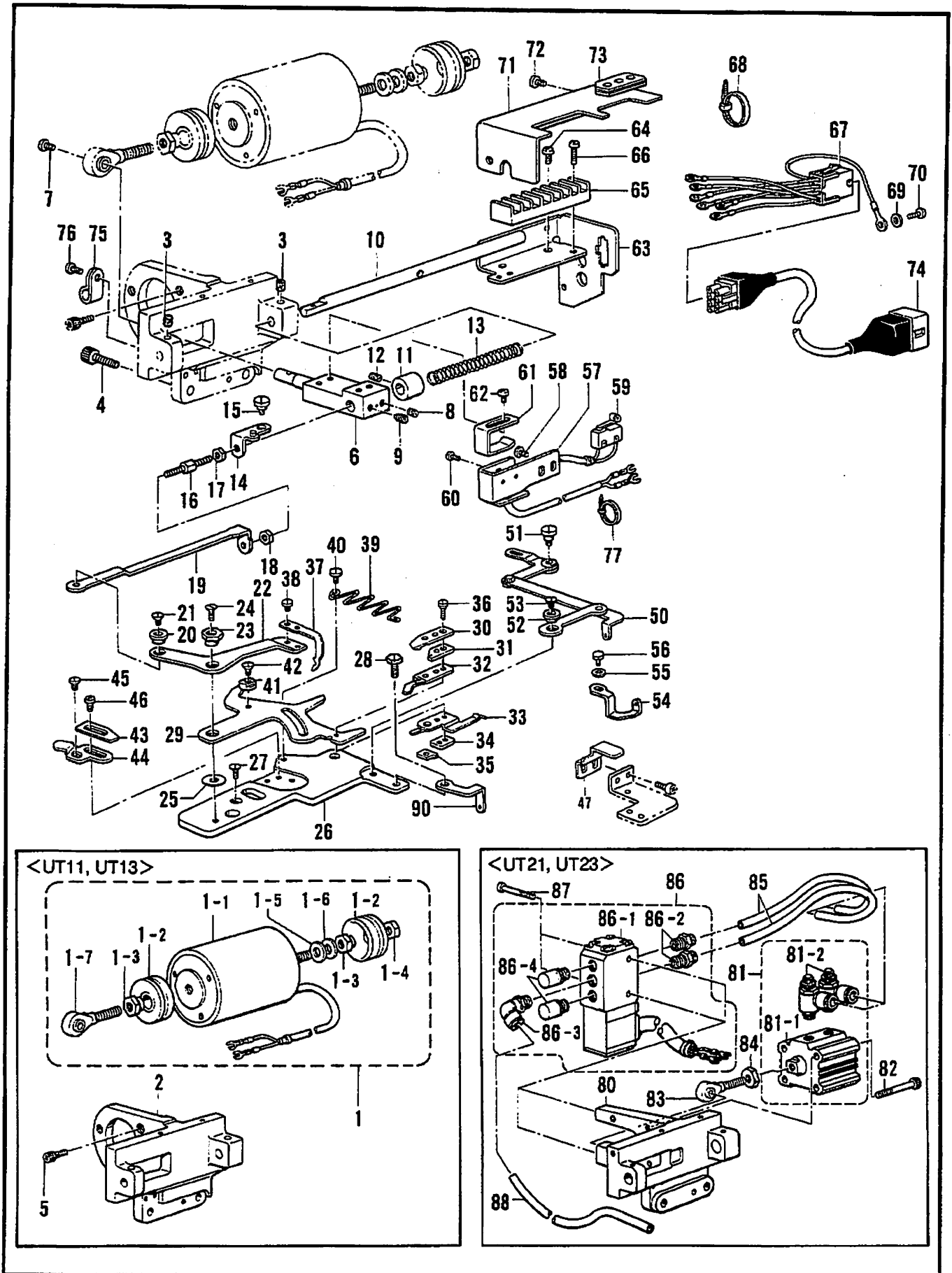

N. 下飾り糸切り関係 / Lower thread trimmer mechanism / Unterefadensabschneider /
Mécanisme de coupe-fils inférieur / Dispositivo de cortahilos inferior

REF.NO.	CODE	Q'TY	ヒンメイ	NAME OF PARTS	RM
3	S09043000	2	フェルト	FELT	
4	018062022	2	アナボルト6X20	BOLT, SOCKET M6X20	
6	S21902001	1	イトキリクドウウデ	THREAD TRIMMER DRIVING ARM	
7	062680512	1	ナベコ437-40X5	SCREW, PAN SM4.37-40X5	
8	014760622	1	アナトメネジ5.95	SET SCREW, SOCKET SM5.95	
9	118853001	1	アナトメネジ5.95	SET SCREW, SOCKET SM5.95	
10	S21903001	1	イトキリクドウジク	THREAD TRIMMER DRIVING SHAFT	
11	104521002	1	セツカラー	SET SCREW COLLAR	
12	014770622	1	アナトメネジ6.35クボミ	SET SCREW, SOCKET (CP) SM6.35	
13	S21904101	1	イトキリフツキバネ	CARRIAGE RETURN SPRING	
14	S21905001	1	クドウレンカンイタ	DRIVING CONNECTOR PLATE	
15	159908001	1	ダンネジ4.37	SHOULDER SCREW, SM4.37	
16	S21906001	1	クドウレンカンジク	DRIVING CONNECTING SHAFT	
17	S21907001	1	ナット5.56	NUT, M5.56	
18	110140001	1	ナット5.56	NUT, M5.56	
19	S21908001	1	クドウレンカン	DRIVING CONNECTOR	
20	S21909001	1	ツギテジク	JOINT SHAFT	
21	117143003	1	サラネジ4.37	SCREW, FLAT M4.37	
22	S21910001	1	シタメスレバー	LOWER KNIFE LEVER	
23	S21911001	1	シテンヘンシンジク	ECCENTRIC SHAFT	
24	107231002	1	サラネジ4.76	SCREW, FLAT SM4.76	
25	S21912000	1	シテンザガネ	WASHER	
26	S21913001	1	シタイトキリドダイ	LOWER THREAD TRIMMER BRACKET	
27	105955002	2	シメネジ4.37	SCREW, M4.37	
28	154574001	1	ボルト4.37	BOLT, SM4.37	
29	S21914001	1	ウワメスレバー	UPPER KNIFE LEVER	
30	S21915001	1	ウワメス	UPPER KNIFE	
31	S21916001	1	カンザ	SPACER	
32	S21917101	1	イトツカミバネ	THREAD CLAMP SPRING	
33	S21918101	1	イトツカミチヨウセツバネ	THREAD CLAMP ADJUST SPRING	
34	S21919001	1	アテイタ	CAUL SPACER	
35	S21920001	1	チヨウセツイタ	ADJUST PLATE	
36	S21921001	3	サラネジ2.38X8	SCREW, FLAT M2.38X8	
37	S21922001	1	シタメス	LOWER KNIFE	
38	106568003	2	シメネジ3.57	SCREW, SM3.57	
39	S21923001	1	ウワメスレバーオシバネ	PUSH SPRING	
40	153222001	1	シメネジ4.37	SCREW, SM4.37	
41	S21924001	1	シタメスストツバ	LOWER KNIFE STOPPER	
42	117143003	1	サラネジ4.37	SCREW, FLAT M4.37	
43	S21925001	1	ウワメスストツバA	UPPER KNIFE STOPPER (A)	
44	S21926001	1	ウワメスストツバB	UPPER KNIFE STOPPER (B)	
45	107419002	1	シメネジ4.37	SCREW, SM4.37	
46	060680712	2	バインド437-40X7	SCREW, BIND SM4.37-40X7	
47	S21927001	1	ウワメスレバーガイド	UPPER KNIFE LEVER GUIDE	
50	S21928001	1	ルーバイトトリレバークミ	LOOPER THREAD TAKE-UP LEVER ASSY	
51	S16385001	1	ダンネジ4.37	SHOULDER SCREW, M4.37	
52	S21909001	1	ツギテジク	JOINT SHAFT	
53	117143003	1	サラネジ4.37	SCREW, FLAT M4.37	
54	S28947001	1	ルーバイトアンナイR	LOOPER THREAD GUIDE	
55	025350236	1	ヒラザガネチユウ3.5	WASHER, PLAIN M 3.5	
56	144075001	1	ボルト3.57	BOLT, SM3.57	
57	S21933001	1	スイッチダイ	SWITCH BASE	
58	060680712	2	バインド437-40X7	SCREW, BIND SM4.37-40X7	
59	S21934001	1	スイッチクミ	SWITCH ASSY	
60	062020805	2	ナベコ2X8	SCREW, PAN M2X8	
61	S21935001	1	スイッチイタ	SWITCH PLATE	
62	060680712	2	バインド437-40X7	SCREW, BIND SM4.37-40X7	
63	S28759001	1	コネクタターミナル	CONNECTOR TERMINAL	
64	060680712	4	バインド437-40X7	SCREW, BIND SM4.37-40X7	

N. 下飾り糸切り関係 / Lower thread trimmer mechanism / Unterefadensabschneider /
 Mécanisme de coupe-fils inférieur / Dispositivo de cortahilos inferior

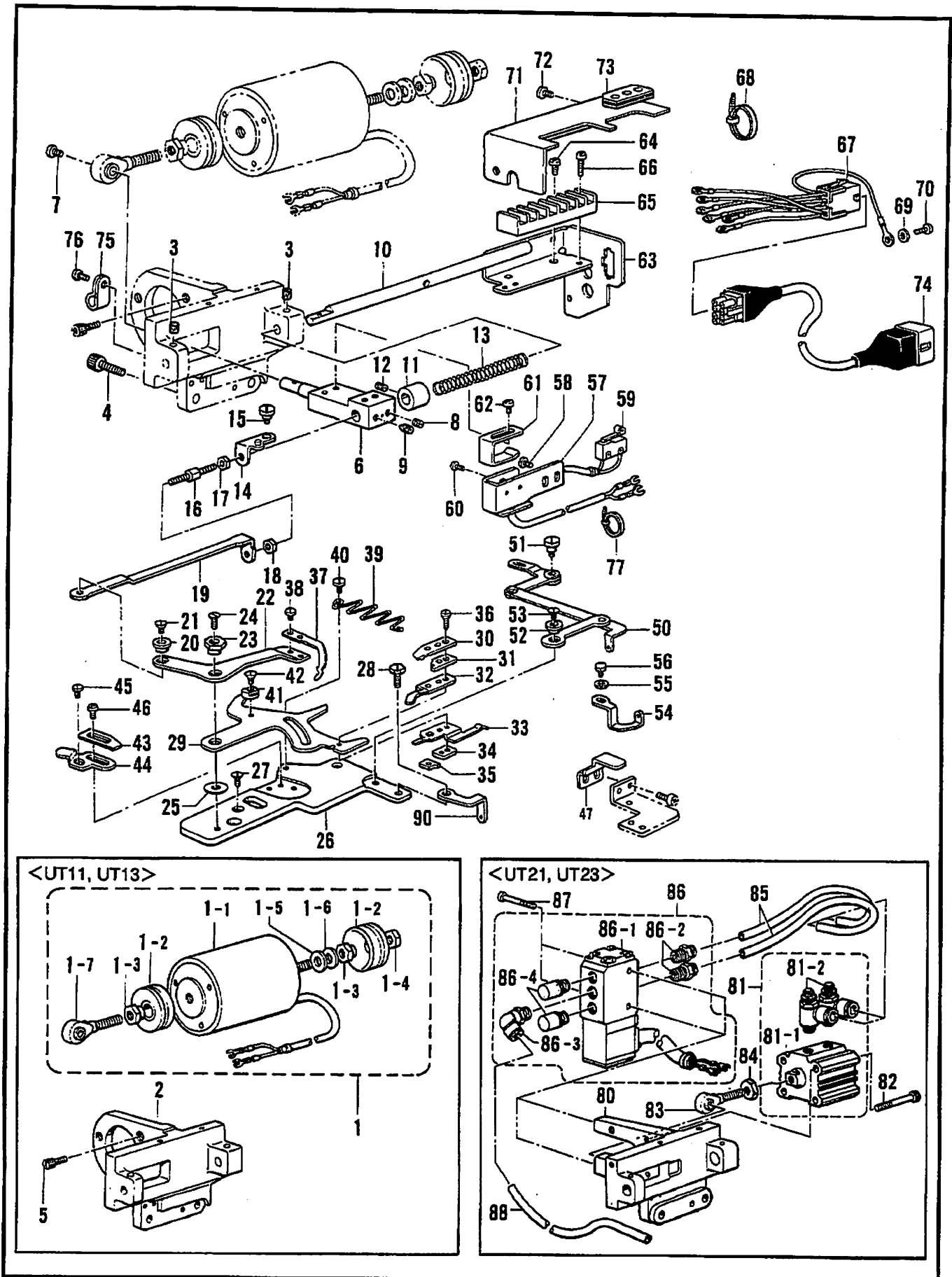

118-266-422

N. 下飾り糸切り関係 / Lower thread trimmer mechanism / Unterefadensabschneider /
 Mécanisme de coupe-fils inférieur / Dispositivo de cortahilos inferior

REF.NO.	CODE	Q'TY	ヒンメイ	NAME OF PARTS	RM
65	S21937001	1	タンシダイ	TERMINAL BLOCK	
66	062301616	2	ナベコM3X16	SCREW, PAN M3X16	
67	S21938001	1	コードクミ	CORD ASSY	
68	S04159000	1	バンド1M	BAND, 1M	
69	S02745001	1	ザガネ	WASHER	
70	062680663	1	ナベコ437-40X6	SCREW, PAN SM4.37-40X6	
71	S28760001	1	コネクターカバー	CONNECTOR COVER	
72	060680512	3	バンド437-40X5	SCREW, BIND SM4.37-40X5	
73	233193001	1	テモトコードブツシング	CORD BUSH	
74	S21940101	1	ケーブルクミ	CABLE ASSY	
75	S25907000	1	コードホルダ#9	CORD HOLDER, #9	
76	062680712	1	ナベコ437-40X7	SCREW, PAN SM4.37-40X7	
77	S04159000	1	バンド1M	BAND, 1M	
90	S28946001	1	ルーバイトアンナイル	LOOPER THREAD GUIDE (L)	

			<UT11,UT13>	<UT11,UT13>	
1	S21895001	1	イトキリソレノイドクミ	THREAD TRIMMER SOLENOID ASSY	
1-1	S21896001	1	イトキリソレノイド	THREAD TRIMMER SOLENOID	
1-2	S21897000	2	ゴムブーツ	RUBBER BOOT	
1-3	S21898001	2	ナツト8	NUT, M8	
1-4	021080302	1	ナツト3シユ8	NUT, 3 M8	
1-5	S21899000	2	ストツバゴム	RUBBER STOPPER	
1-6	025080232	1	ヒラザガネチユウ8	WASHER, PLAIN M 8	
1-7	S21900001	1	ロツドエンド	ROD END	
2	S21901001	1	イトキリソレノイドドダイ	THREAD TRIMMER SOLENOID BASE BRACKET	
5	018501222	3	アナボルト5X12	BOLT, SOCKET M5X12	

			<UT21,UT23>	<UT21,UT23>	
80	S28678001	1	イトキリシリンダードダイ	THREAD TRIMMER CYLINDER BRACKET	
81	S28670000	1	エアシリンダクミ	AIR CYLINDER ASSY	
81-1	S28671000	1	エアシリンダ	AIR CYLINDER	
81-2	S28599000	2	スピードコントローラ	SPEED CONTROLLER	
82	415006002	4	アナボルト5X40	BOLT, SOCKET M5X40	
83	S21900001	1	ロツドエンド	ROD END	
84	021080302	1	ナツト3シユ8	NUT, 3 M8	
85	S28674000	2	エアチューブ	AIR TUBE (L= 200)	
86	S28675000	1	ソレノイドバルブクミ	SOLENOID VALVE ASSY	
86-1	S28676000	1	ソレノイドバルブ	SOLENOID VALVE	
86-2	S01522000	2	ハーフユニオン	HALF UNION	
86-3	S01542000	1	エルボユニオン61	ELBOW UNION, 61	
86-4	159874000	2	サイレンサー	SILENCER	
87	062303012	2	ナベコM3X30	SCREW, PAN M3X30	
88	S28677000	1	エアチューブ	AIR TUBE (L= 1000)	

a. 電磁押工上げ関係 / Presser foot lifting solenoid set / Solenoidsatz für die anhebung des stoffdrückerfußes / Jeu de solénoïde du releveur du pied pressur / Conjunto solenoide del levantador

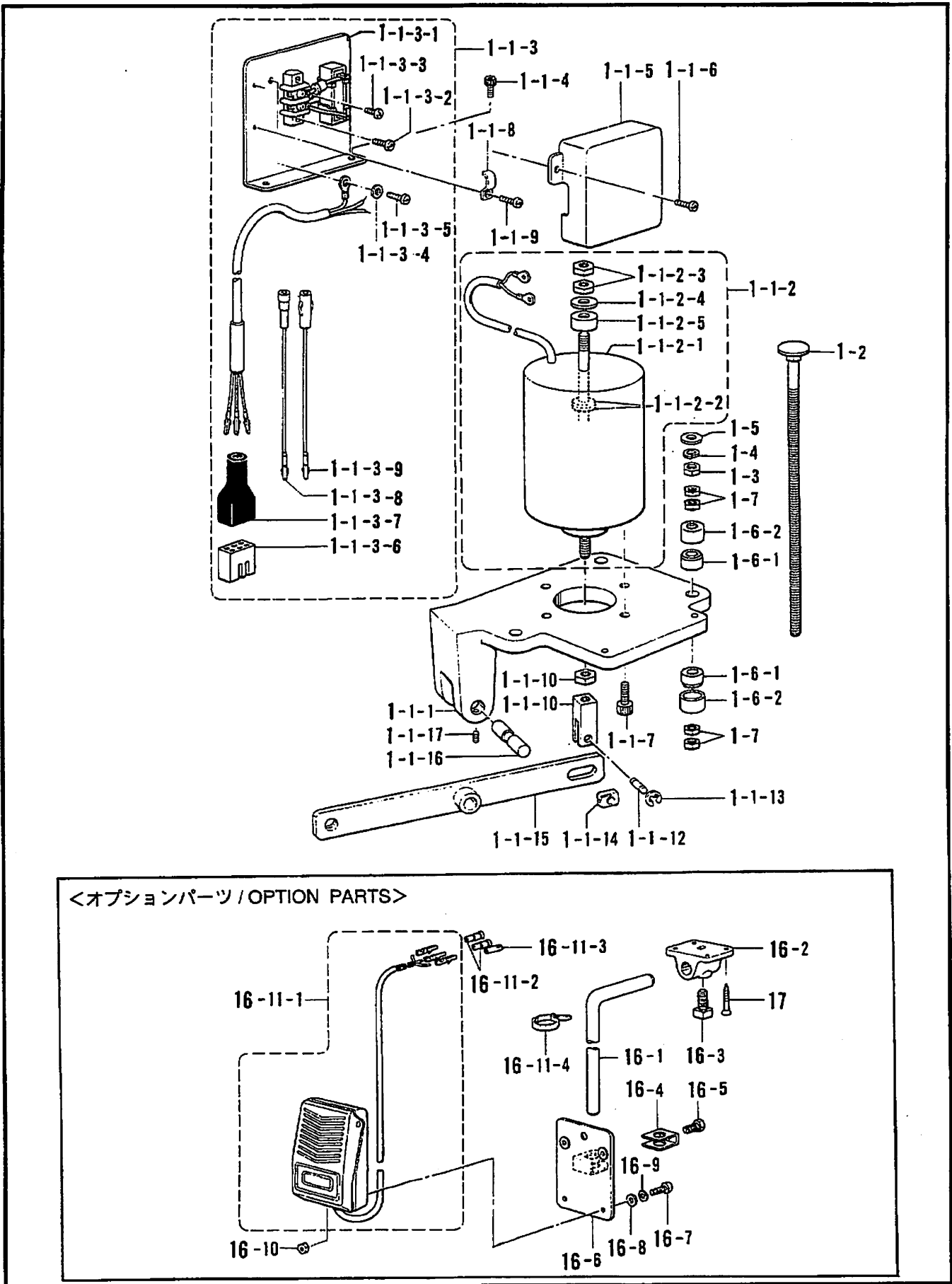

a. 電磁押工上げ関係 / Presser foot lifting solenoid set / Solenoidsatz für die anhebung des stoffdrückerfußes / Jeu de solénoïde du releveur du pied pressur / Conjunto solenoide del levantador

REF.NO.	CODE	Q'TY	ヒンメイ	NAME OF PARTS	RM
1	183796401	1	デンジオサエアゲセットB	SOLENOID PRESSER FOOT LIFTING	
1-1	S21946301	1	デンジオサエアゲクミ	SOLENOID PRESSER FOOT LIFTING ASSY	
1-1-1	S21947001	1	ソレノイドダイ	SOLENOID BRACKET	
1-1-2	S21948101	1	オサエアゲソレノイドクミ	PRESSER FOOT LIFTING SOLENOID ASSY	
1-1-2-1	S21949101	1	オサエアゲソレノイド	PRESSER FOOT LIFTING SOLENOID	
1-1-2-2	S21899000	2	ストツバゴム	RUBBER STOPPER	
1-1-2-3	021080302	2	ナツト3シユ8	NUT, 3 M8	
1-1-2-4	025080232	1	ヒラザガネチユウ8	WASHER, PLAIN M 8	
1-1-2-5	S28821000	1	カンシヨウゴム	CUSHION RUBBER	
1-1-3	S21950009	1	タンシダイベースクミ	TERMINAL BLOCK BASE ASSY	
1-1-3-1	S21951001	1	タンシダイベース	TERMINAL BLOCK BASE	
1-1-3-2	062671012	2	ナベコ357-40X10	SCREW, PAN SM3.57-40X10	
1-1-3-3	062670612	1	ナベコ357-40X6	SCREW, PAN SM3.57-40X6	
1-1-3-4	S02745001	1	ザガネ	WASHER	
1-1-3-5	062680663	1	ナベコ437-40X6	SCREW, PAN SM4.37-40X6	
1-1-3-6	143522000	1	ナイロンコネクタ-	NYLON CONNECTOR	
1-1-3-7	220077001	1	プラグカバー-#14	PLUG COVER, #14	
1-1-3-8	S05981000	1	Bコード100クミ2	B-CORD ASSY, 100 (2)	
1-1-3-9	S05982000	1	Wコード100クミ	W-CORD ASSY, 100	
1-1-4	018400832	2	アナボルト4X8	BOLT, SOCKET M4X8	
1-1-5	S02592059	1	タンシダイカバー	TERMINAL BLOCK COVER	
1-1-6	062670612	2	ナベコ357-40X6	SCREW, PAN SM3.57-40X6	
1-1-7	018061631	4	アナボルト6X16	BOLT, SOCKET M6X16	
1-1-8	142268001	1	コードオサエL	CORD HOLDER, L	
1-1-9	062670612	1	ナベコ357-40X6	SCREW, PAN SM3.57-40X6	
1-1-10	021080302	1	ナツト3シユ8	NUT, 3 M8	
1-1-11	S21953001	1	ソレノイドツギテ	SOLENOID JOINT	
1-1-12	S09637001	1	ピン	PIN	
1-1-13	048040342	2	トメワE4	RETAINING RING, E4	
1-1-14	102630001	1	ハリボウアンナイカクコマ	NEEDLE BAR GUIDE SLIDE BLOCK	
1-1-15	S21954001	1	オサエアゲレバー	PRESSER BAR LIFTER LEVER	
1-1-16	S21955001	1	オサエアゲレバージク	PRESSER BAR LIFTER SHAFT	
1-1-17	014710522	2	アナトメネジ4.76クボミ	SET SCREW, SOCKET (CP) SM4.76	
1-2	S21952101	3	カクネマルアタマボルト	BOLT	
1-3	021080106	3	ナツト1シユ8	NUT, 1 M8	
1-4	028080242	3	バネザガネ2-8	WASHER, SPRING 2-8	
1-5	025080236	3	ヒラザガネチユウ8	WASHER, PLAIN M 8	
1-6	146254001	6	モータカンザ	COLLAR	
1-6-1	146255000	6	クツシヨン	CUSHION	
1-6-2	146256001	6	クツシヨソカナグ	CUSHION COLLAR	
1-7	021080302	12	ナツト3シユ8	NUT, 3 M8	
			"オプションパーツ"	"OPTION PARTS"	
16	S07045009	1	ヒザスイツチクミ	KNEE SWITCH ASSY	
16-1	142026003	1	ヒザスイツチタテジク	KNEE SWITCH SHAFT	
16-2	142027001	1	ヒザスイツチタテジクウケ	KNEE SWITCH SHAFT BRACKET	
16-3	100463001	1	カクボルト7.94	BOLT, SM7.94	
16-4	114967001	1	ヒザアテストツバ	KNEE LIFTER PLATE STOPPER	
16-5	110087001	1	ボルト5.95	BOLT, SM5.95	
16-6	S07027001	1	ヒザスイツチトリツケイタ	KNEE LIFTER SWITCH PLATE	
16-7	062401006	4	ナベコ4X10	SCREW, PAN M4X10	
16-8	025040233	4	ヒラザガネチユウ4	WASHER, PLAIN M 4	
16-9	028040243	4	バネザガネ2-4	WASHER, SPRING 2-4	
16-10	021400164	4	ナツト1シユ4	NUT, 1 M4	
16-11	S07030009	1	スイツチコードクミ	SWITCH CORD ASSY	
16-11-1	S07031009	1	フツスイツチクミ	FOOT SWITCH ASSY	
16-11-2	146046000	2	ナイロンコネクタ	NYLON CONNECTOR	
16-11-3	146194000	1	ナイロンコネクタ-	NYLON CONNECTOR	
16-11-4	149799000	1	タイラツプS	BEAD BAND, S	
17	034422503	4	+サラモクネジ4.1X25	WOOD SCREW, FLAT M4.1X25	
電磁押え上げセットA(ヒザスイツチ付)/ SOLENOID PRESSER FOOT LIFTING SET A				183795-401	
電磁押え上げセットB(ヒザスイツチ無)/ SOLENOID PRESSER FOOT LIFTING SET B				183796-401	

b. エアー押エ上げ関係 / Pneumatic presser foot lifting mechanism / Pneumatische stoffdrückerfußanhebevorrichtung / Dispositif pneumatique de releveur de pied presseur / Levantador neumático del prensatelas

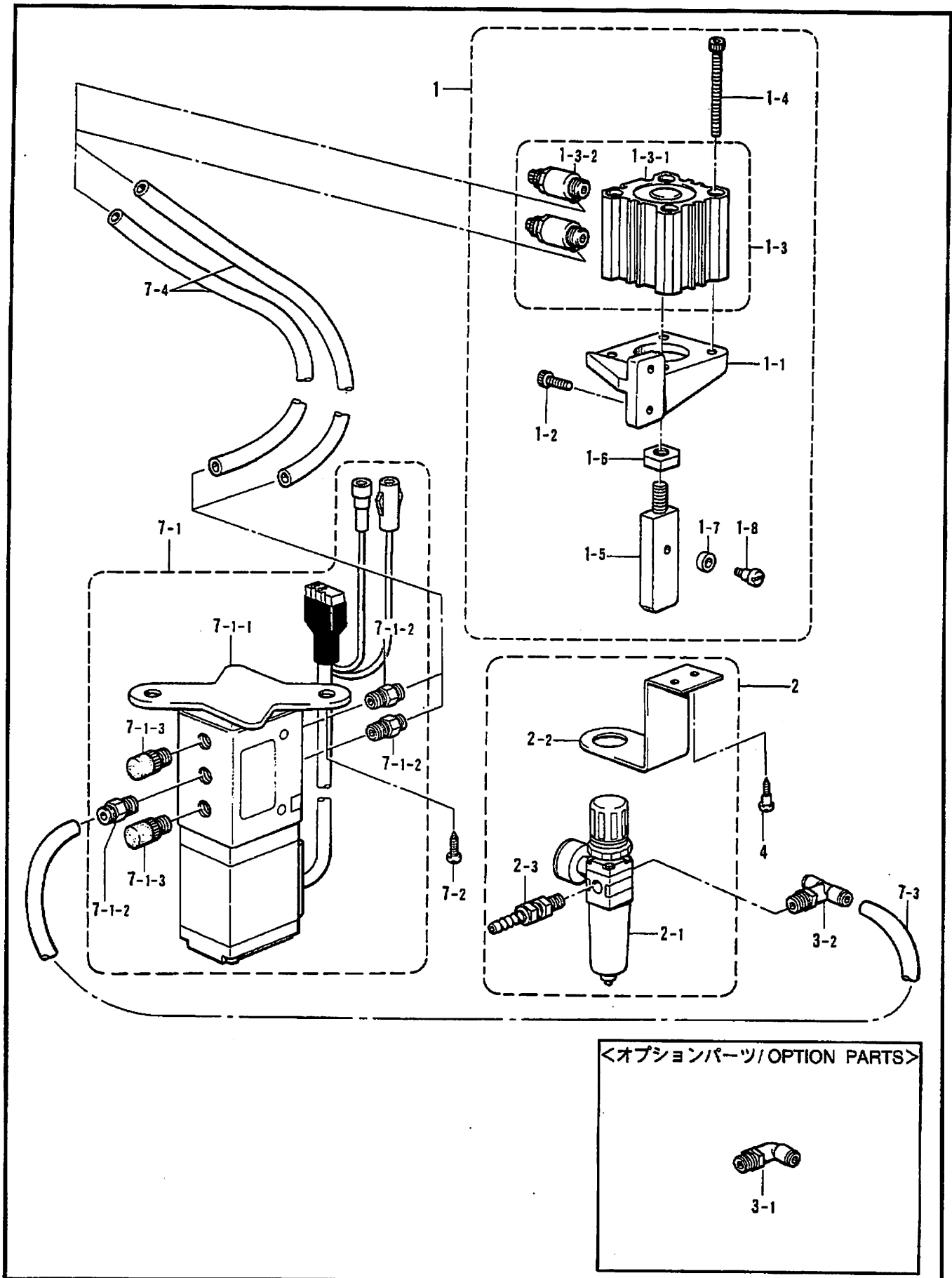

118-266-959

b. エアー押え上げ関係 / Pneumatic presser foot lifting mechanism / Pneumatische stoffdrückerfußanhebvorrichtung / Dispositif pneumatique de releveur de pied presseur / Levantador neumático del prensatelas

REF.NO.	CODE	Q'TY	ヒンメイ	NAME OF PARTS	RM
1	S28681001	1	オサエアゲシリンダクミ	PRESSER FOOT LIFTING SYLINDER ASSY	
1-1	S28596001	1	シリンダードダイ	CYLINDER BASE	
1-2	018061222	2	アナボルト6X12	BOLT, SOCKET M6X12	
1-3	S28597000	1	エアーシリンダクミ	AIR CYLINDER ASSY	
1-3-1	S28598000	1	エアーシリンダ	AIR CYLINDER	
1-3-2	S28599000	2	スピードコントローラ	SPEED CONTROLLER	
1-4	018505022	4	アナボルト5X50	BOLT, SOCKET M5X50	
1-5	S28600001	1	オサエサドウボウ	PRESSER DRIVING BAR	
1-6	021080302	1	ナツト3シユ8	NUT, 3 M8	
1-7	110167001	1	コロ	ROLLER	
1-8	110168001	1	コロジク	ROLLER SHAFT	
2	S28468001	1	エアーユニットクミ	AIR UNIT ASSY	
2-1	S21352000	1	フィルターレギュレータ	FILTER REGULATOR	
2-2	S21353001	1	エアーユニットトリツケイタ	AIR UNIT SET PLATE	
2-3	140678000	1	ホースツギテ	AIR TUBE JOINT	
3-2	S28469000	1	チーズユニオン	T-UNION (2)	
4	101118001	2	マルモクネジ4.5X20	WOOD SCREW, ROUND M4.5X20	
7	S28682001	1	オサエアゲバルブセット	PRESSER FOOT LIFTING VALVE SET	
7-1	S28683001	1	オサエアゲバルブクミ	PRESSER FOOT LIFTING VALVE ASSY	
7-1-1	S28680001	1	ソレノイドバルブクミ	SOLENOID VALVE ASSY	
7-1-2	S01522000	3	ハーフユニオン	HALF UNION	
7-1-3	159874000	2	サイレンサー	SILENCER	
7-2	032422505	2	+マルモクネジ4.1X25	WOOD SCREW, ROUND M4.1X25	
7-3	S28685000	1	エアーチューブ (L=310)	AIR TUBE (L=310)	
7-4	S28686000	2	エアーチューブ (L=900)	AIR TUBE (L=900)	
3-1	S04896000	1	"オプションパーツ" エルボユニオン	"OPTION PARTS" ELBOW UNION (1)	
エアー押え上げセット/ PNEUMATIC PRESSER FOOT LIFTING SET				183795-401	

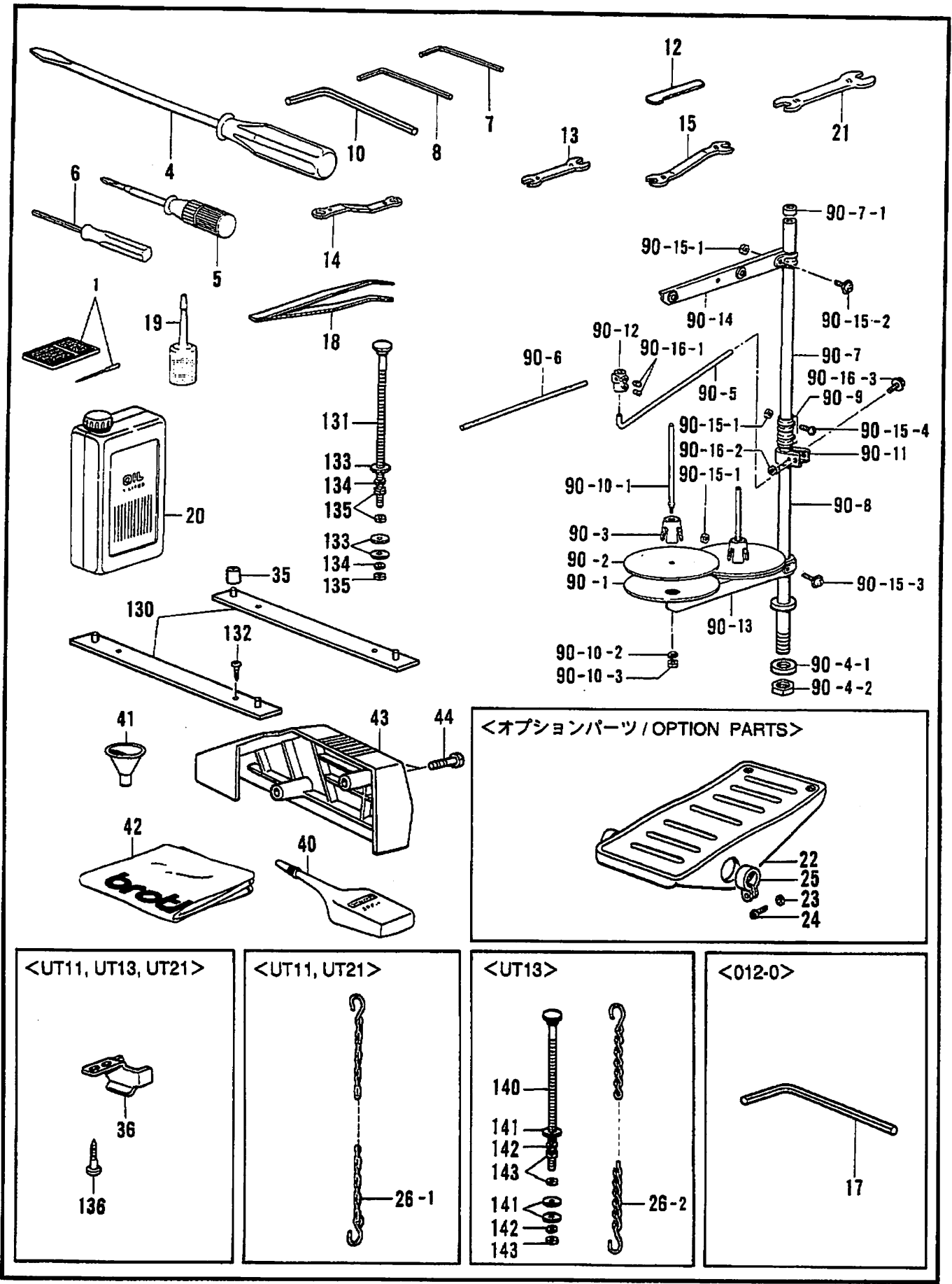

<オプションパーツ / OPTION PARTS>

<UT11, UT13, UT21>

<UT11, UT21>

<UT13>

<012-0>

Z. 付属品関係 / Accessories / Zubehör / Accessoires / Accesorios



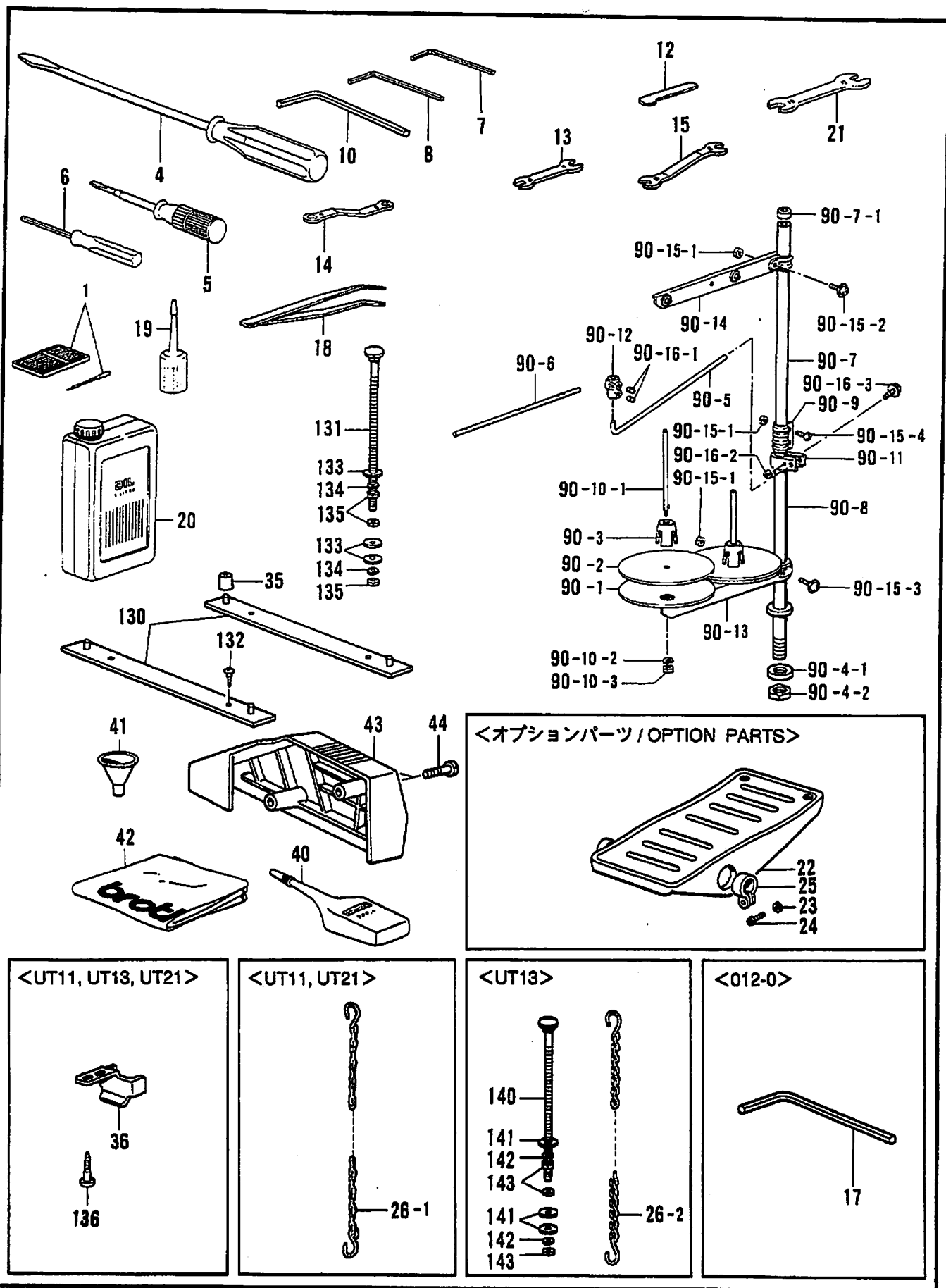









REF.NO.	CODE	Q'TY	ヒンメイ	NAME OF PARTS
1	508715016	10	ミシンハリUYX128GAS	NEEDLE, UYX128GAS (#16)
4	101572101	1	ネジマワシ5.5X190	SCREW DRIVER, 5.5X190
5	118837001	1	ネジマワシ3.4X70	SCREW DRIVER, 3.4X70
6	501943001	1	6カクボウネジマワシ1.6	SCREW DRIVER, 1.6
7	146049001	1	6カクボウスパナ2	HEXAGONAL WRENCH, 2
8	142721001	1	6カクボウスパナ3	HEXAGONAL WRENCH, 3
10	150335001	1	6カクボウスパナ5	HEXAGONAL WRENCH, 5
12	156309001	1	Lガタネジマワシ	L-TYPE SCREW DRIVER
13	107779001	1	スパナ6X7	WRENCH, 6X7
14	105343001	1	メガネレンチ8X9	WRENCH, 8X9
15	143566001	1	スパナ8	WRENCH, 8
18	117466000	1	ピンセット	PINCETTE
19	S06701000	1	ポリオイラークミ	POLY OILER ASSY
20	145277205	1	オイルタンク	OIL TANK
21	107780001	1	スパナ10X12	WRENCH, 10X12
35	147919001	4	ボウシンゴム	RUBBER CUSHION
40	S06704001	1	シリコンオイル	SILICONE OIL
41	140759000	1	ジョーゴ	FUNNEL
42	144224001	1	トубカバー	HEAD COVER
43	S09002009	1	ベルトカバー	BELT COVER
44	102424004	2	シメネジ4.37	SCREW, M4.37
90	S40574009	1	イトタテダイクミ2DTHF	COTTON STAND ASSY 2DTHF
90-1	150180001	2	ウケザラ	SPOOL STAND BASE
90-2	150182000	2	スプールのマット	SPOOL MAT
90-3	126863001	2	スプールのクッション	SPOOL CUSHION
90-4	S02775001	1	パイプネジセットA	PIPE SCREW SET, A
90-4-1	150206002	1	ヒラザガネ16	WASHER, PLAIN 16
90-4-2	S38648001	1	6カクナツU5/8	NUT, U5/8-28
90-5	S04109001	1	イトアンナイササエボウ	THREAD GUIDE SUPPORT BAR
90-6	142997001	1	イトアンナイ3	THREAD GUIDE, 3
90-7	S40640001	1	コラムパイプキャップツキ	COLUMN PIPE WITH CAP
90-7-1	150174000	1	コラムキャップ	COLUMN CAP
90-8	156112003	1	コラムパイプD	COLUMN PIPE, D
90-9	150173003	1	コラムジョイント	COLUMN JOINT
90-10	S21798001	2	スプールのネジセット	SPOOL SCREW SET
90-10-1	150179002	2	スプールのジク8	SPOOL SHAFT, B
90-10-2	028050246	2	バネザガネ2-5	WASHER, SPRING 2-5
90-10-3	021500106	2	1シユナツト5	NUT, 1 M5
90-11	150185009	1	イトアンナイホルダー	THREAD GUIDE HOLDER
90-12	138843001	1	ササエボウツギテ	JOINT
90-13	S02778002	1	スプールのホルダー2	SPOOL HOLDER, 2
90-14	S02786002	1	スレッドハンガークミ2	THREAD HANGER ASSY, 2
90-15	S40641001	1	スプールのジクネジセットA	SPOOL SCREW SET, A
90-15-1	021500106	4	1シユナツト5	NUT, 1 M5
90-15-2	S37038001	1	ナベコヒラザ5X14	SCREW, PAN (P WASHER) M5X14
90-15-3	S37037001	1	ナベコヒラザ5X32	SCREW, PAN (P WASHER) M5X32
90-15-4	062501406	2	ナベコ5X14	SCREW, PAN M5X14
90-16	S40643001	1	ホルダーツギテネジセット	HOLDER JOINT SCREW SET
90-16-1	014060632	2	アナトメ6X6クボミ	SET SCREW, SOCKET (CP) M6X6
90-16-2	021500106	1	1シユナツト5	NUT, 1 M5
90-16-3	S37037001	1	ナベコヒラザ5X32	SCREW, PAN (P WASHER) M5X32
130	S11561001	2	トубウケイタ	HEAD SPOOL PLATE
131	S11562001	4	カクネマルアタマボルト	BOLT
132	100666002	4	マルモクネジ5.5X20	WOOD SCREW, ROUND M5.5X20
133	025080336	12	ヒラザガネダイ8	WASHER, PLAIN L8
134	028080242	8	バネザガネ2-8	WASHER, SPRING 2-8
135	021080106	12	ナツト1シユ8	NUT, 1 M8
			<012-0>	<012-0>
17	118064001	1	6カクボウスパナ4	HEXAGONAL WRENCH, 4

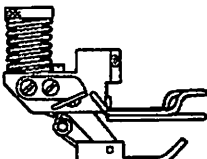
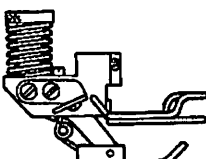

Z. 付属品関係 / Accessories / Zubehör / Accessoires / Accesorios

REF.NO.	CODE	Q'TY	ヒンメイ	NAME OF PARTS	R/M
26-1	149247001	1	<UT11,UT21> クサリクミ	<UT11,UT21> CHAIN ASSY	
26-2	S21942001	1	<UT13> クサリクミ	<UT13> CHAIN ASSY	
140	S11562001	1	カクネマルアタマボルト	BOLT	
141	025080336	3	ヒラザガネダイ8	WASHER, PLAIN L 8	
142	028080242	2	バネザガネ2-8	WASHER, SPRING 2-8	
143	021080106	3	ナツト1シユ8	NUT, 1 M8	
36	S09001101	1	<UT11,UT13,UT21> クサリガイド	<UT11,UT13,UT21> CHAIN GUIDE	
136	032461606	2	+マルモクネジ4.5X16 "オプションパーツ"	WOOD SCREW, ROUND M4.5X16 "OPTION PARTS"	
22	147893009	1	オサエアゲフミイタ	TREADLE PEDAL	
23	021400106	2	ナツト1シユ4	NUT, 1 M4	
24	062401406	2	ナベコ4X14	SCREW, PAN M4X14	
25	116016001	2	ペタルトメ	PEDAL STOPPER	

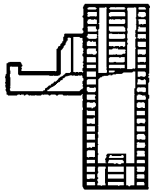
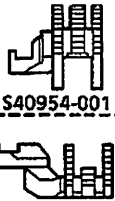
ゲージ部品一覧表/GAUGE PARTS LIST/LEHRENLISTE/
LISTEDES PIECES P'ECARTEMENT/LISTA DE PIEZAS CALIBRADORAS

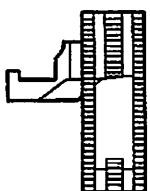
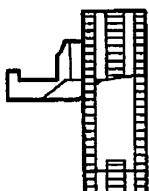
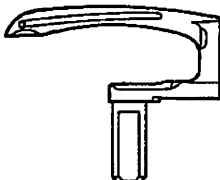
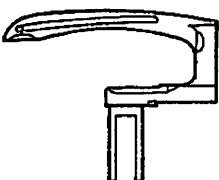
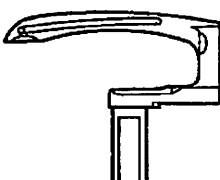
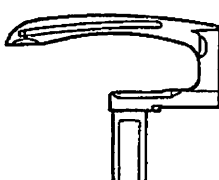
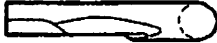
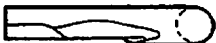
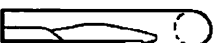
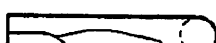
仕様 Specifications	012-0	0D2-0	for 012-0	for 012-0
仕様ラベル Label	S28933-003	S28933-006	Option	Option
用途 Application	地縫用 Plain Stitching	地縫用 Plain Stitching	地縫用(薄物用フィーディングフット付) Plain Stitching (Thin W / Feeding Presser Foot)	地縫用(中厚用フィーディングフット付) Plain Stitching (Medium Thick W / Feeding Presser Foot)
針数(本) No. of Needles	1	1	1	1
針巾(mm) Needle Spacing (mm)	-	-	-	-
針止メ組 Needle Clamp Assembly	 S17480-101	 S17480-101	 S17480-101	 S17480-101
押し組 Presser Foot Assembly	 S40541-101	 S40952-101	 S40548-001	 S40548-001
針板 Needle Plate	 S40538-001	 S40538-001	 S40538-001	 S40538-001
送り歯 Feed Dog	 S40565-001	 S40954-001  S40955-001	 S40564-001	 S40565-001
ルーパー Looper	 S40569-001	 S40569-001	 S40569-001	 S40569-001
ハリウケ Needle Guard	 S08756-001	 S08756-001	 S08756-001	 S08756-001

索引 / INDEX / VERZEICHNIS
/ INDEX / INDICE

CODE	REF.NO.	Page
J80347001	G - 1	8
S00017001	A - 102	4
S00075000	A - 90-3	2
S00313009	A - 27	2
	A - 123	4
S00356001	M - 51	28
S00383001	M - 52	28
S00879001	D - 25	10
S01522000	N - 86-2	34
	b - 7-1-2	38
S01542000	N - 86-3	34
S01943001	Z - 6	40
S02592059	a - 1-1-5	36
S02606000	A - 5	2
S02745001	N - 69	34
	a - 1-1-3-4	36
S02775001	Z - 90-4	40
S02778002	Z - 90-13	40
S02786002	Z - 90-14	40
S03704002	B - 50	6
	E - 46	14
	J - 28	20
S04109001	Z - 90-5	40
S04159000	N - 68	34
	N - 77	34
S04896000	b - 3-1	38
S05981000	a - 1-1-3-8	36
S05982000	a - 1-1-3-9	36
S06701000	Z - 19	40
S06704001	Z - 40	40
S07027001	a - 16-6	36
S07030009	a - 16-11	36
S07031009	a - 16-11-1	36
S07045009	a - 16	36
S07317001	A - 90-6	2
S08467000	E - 70	14
S08627001	A - 2	2
S08628000	A - 3	2
S08631000	A - 16	2
S08633101	A - 29	2
S08639000	A - 39	2
S08642001	A - 42	2
S08646100	A - 44	2
S08651001	A - 46	2
S08652000	A - 47	2
S08653001	A - 52	2
S08665001	A - 100	4
S08667001	A - 105	4
S08668001	A - 108	4
S08670000	A - 116	4
S08672000	A - 120	4
S08673000	A - 124	4
	A - 128	4
S08674000	A - 138	4
S08675000	A - 139	4
S08682001	B - 3	6
S08683000	B - 4	6
S08684101	B - 6	6
S08685001	B - 6-1	6
S08686101	B - 6-2	6
S08687001	B - 8	6
S08688001	B - 9	6
S08689001	B - 11	6

CODE	REF.NO.	Page
S08692101	B - 16	6
S08693001	B - 16-1	6
S08694001	B - 16-2	6
S08695001	B - 16-4-1	6
S08696000	B - 23	6
S08697000	B - 24	6
S08698001	B - 25	6
S08715016	B - 31	6
	Z - 1	40
S08716301	B - 35	6
S08750001	B - 42	6
S08751001	B - 44	6
S08752001	B - 46	6
S08753000	B - 48	6
S08754000	B - 49	6
	J - 27	20
S08755101	B - 51	6
S08756001	B - 53	6
S08758109	C - 1	8
S08760009	C - 1-1	8
S08761100	C - 3	8
S08769001	D - 6	10
S08770000	D - 12	10
	J - 7	20
	M - 49	28
S08771001	D - 14	10
S08774001	D - 18	10
S08775000	D - 28	10
S08776001	D - 30	10
S08777001	D - 31	10
S08870001	E - 8	14
S08871001	E - 10	14
S08872001	E - 20-2	16
S08873001	E - 20-2-1	16
S08876000	E - 36	14
S08877001	E - 44	14
S08878001	E - 54	16
S08879001	E - 57	16
S08880001	E - 58	16
S08881101	E - 64	16
S08889101	H - 1	18
S08890001	H - 1-1	18
S08891001	H - 5	18
S08892001	H - 8	18
S08895002	H - 10	18
S08896101	H - 11	18
S08897001	H - 11-1	18
S08898000	H - 13	18
S08899001	H - 14	18
S08900000	H - 16	18
S08903000	H - 17	18
S08904000	H - 20	18
S08911000	J - 8	20
S08912001	J - 10	20
S08914001	J - 20	20
S08915001	J - 23	20
S08916001	J - 25	20
S08917000	J - 26	20
S08918001	J - 29	20
S08919001	J - 32	20
S08920001	J - 33	20
S08921101	J - 35	20
S08935001	K - 1	22

CODE	REF.NO.	Page
S08936201	K - 3	22
S08937101	K - 3-4	22
S08939100	K - 3-6	22
S08940000	K - 6	22
S08943000	K - 12	22
S08944001	K - 13	22
S08945001	K - 16	22
S08946000	K - 18	22
S08948001	K - 22	22
S08951001	K - 26	22
S08953001	K - 37	22
S08955051	K - 32	22
S08956100	K - 34	22
S08957001	K - 35	22
S08958001	K - 40	22
S08961101	M - 1	28
S08962109	M - 7	28
S08963001	M - 10	28
S08964001	M - 11	28
S08967001	H - 19	18
S08969201	M - 40	28
S08970001	M - 91	28
S08971201	M - 45	28
S08976001	M - 50	28
S08977001	M - 54	28
S08978001	M - 57	28
S08981001	M - 68	28
S08982001	M - 70	28
S08983001	M - 72	28
S08984001	M - 73-2	30
S08987001	M - 104	30
S08992001	M - 102	30
S08993101	M - 108	30
S08994001	M - 111	30
S09001101	Z - 36	42
S09002009	Z - 43	40
S09043000	N - 3	32
S09120001	B - 16-3	6
S09121001	B - 41	6
S09123101	A - 38	2
S09124001	B - 38	6
S09125001	K - 45	22
S09251001	J - 35-1	20
S09316000	K - 42	22
S09637001	a - 1-1-12	36
S10243000	L - 29	26
S10774001	A - 14	2
S11561001	Z - 130	40
S11562001	Z - 131	40
	Z - 140	42
S12882001	M - 128	30
S13085001	D - 40-2-6	12
S13385001	B - 39	6
S14085011	L - 25	26
S14621001	B - 1-2	6
S14622001	H - 1-2	18
S14623001	H - 11-2	18
S16249001	E - 80	14
S16385001	N - 51	32
S16498001	E - 1-1	14
S17480201	B - 30	6
S18530001	M - 94	28
S18532001	M - 96	28

索引 / INDEX / VERZEICHNIS
/ INDEX / INDICE

CODE	REF.NO.	Page
S18534001	M -98	28
S18535001	M -100	30
S20118151	D -40-1-2	12
	D -40-2-12	12
	D -40-3-2	12
S21352000	b -2-1	38
S21353001	b -2-2	38
S21798001	Z -90-10	40
S21813051	A -34	2
S21814001	A -37	2
S21815001	A -40	2
S21816001	A -45	2
S21829001	D -1	10
S21830001	D -2	10
S21869101	L -3	26
S21872101	L -6	26
S21873001	L -8	26
S21874000	L -9	26
S21875001	L -10	26
S21877001	L -14	26
S21879001	M -27	28
S21880001	M -28	28
S21881001	M -29	28
S21882001	M -30	28
S21883001	M -31	28
S21884001	M -131	30
S21885001	M -133	30
S21886001	M -135	30
S21887001	M -136	30
S21888001	M -139	30
S21891001	M -140	30
S21893001	M -142	30
S21894001	M -145	30
S21895001	N -1	34
S21896001	N -1-1	34
S21897000	N -1-2	34
S21898001	N -1-3	34
S21899000	N -1-5	34
	a -1-1-2-2	36
S21900001	N -1-7	34
	N -83	34
S21901001	N -2	34
S21902001	N -6	32
S21903001	N -10	32
S21904101	N -13	32
S21905001	N -14	32
S21906001	N -16	32
S21907001	N -17	32
S21908001	N -19	32
S21909001	N -20	32
	N -52	32
S21910001	N -22	32
S21911001	N -23	32
S21912000	N -25	32
S21913001	N -26	32
S21914001	N -29	32
S21915001	N -30	32
S21916001	N -31	32
S21917101	N -32	32
S21918101	N -33	32
S21919001	N -34	32
S21920001	N -35	32
S21921001	N -36	32

CODE	REF.NO.	Page
S21922001	N -37	32
S21923001	N -39	32
S21924001	N -41	32
S21925001	N -43	32
S21926001	N -44	32
S21927001	N -47	32
S21928001	N -50	32
S21933001	N -57	32
S21934001	N -59	32
S21935001	N -61	32
S21937001	N -65	34
S21938001	N -67	34
S21940101	N -74	34
S21942001	Z -26-2	42
S21946301	a -1-1	36
S21947001	a -1-1-1	36
S21948101	a -1-1-2	36
S21949101	a -1-1-2-1	36
S21950009	a -1-1-3	36
S21951001	a -1-1-3-1	36
S21952101	a -1-2	36
S21953001	a -1-1-11	36
S21954001	a -1-1-15	36
S21955001	a -1-1-16	36
S21959001	A -119	4
S21988001	L -42	26
S23359001	E -22	16
	E -27	14
S23660000	L -24	26
S24021000	L -28	26
S25818001	M -129	30
S28438001	M -73-1	28
S28468001	b -2	38
S28469000	b -3-2	38
S28596001	b -1-1	38
S28597000	b -1-3	38
S28598000	b -1-3-1	38
S28599000	N -81-2	34
	b -1-3-2	38
S28600001	b -1-5	38
S28670000	N -81	34
S28671000	N -81-1	34
S28674000	N -85	34
S28675000	N -86	34
S28676000	N -86-1	34
S28677000	N -88	34
S28678001	N -80	34
S28680001	b -7-1-1	38
S28681001	b -1	38
S28682001	b -7	38
S28683001	b -7-1	38
S28685000	b -7-3	38
S28686000	b -7-4	38
S28744000	L -26	26
S28759001	N -63	32
S28760001	N -71	34
S28798001	D -41-1	10
S28800001	D -41-2	10
S28802001	A -90	2
S28803001	A -90-1	2
S28804001	A -90-2	2
S28809201	A -20	2
S28810051	A -15	2

CODE	REF.NO.	Page
S28821000	a -1-1-2-5	36
S28897001	L -20	26
S28898001	L -21	26
S28899001	L -23	26
S28902000	L -27	26
S28946001	N -90	34
S28947001	N -54	32
S28957001	B -1	6
S28958001	B -1-1	6
S28963001	G -3	8
S30086001	B -16-4	6
S30564000	M -17	28
S30565003	M -21	28
	M -23	28
S31012001	D -19	10
S31013001	D -20	10
S36894000	D -40-2-14	12
S37037001	Z -90-15-3	40
	Z -90-16-3	40
S37038001	Z -90-15-2	40
S38648001	Z -90-4-2	40
S39086001	E -34	14
S40532001	A -12	2
S40533001	A -115	4
S40535001	A -65	2
S40538001	B -40	6
S40539001	D -35	12
S40544101	D -40-2-2	12
S40546001	D -40-1-4	12
	D -40-3-4	12
S40549101	D -40-2-1	12
S40555001	D -40-2-3	12
S40556001	D -40-2-4	12
S40557001	D -40-2-10	12
S40558001	D -40-2-9	12
S40559001	E -47	16
S40562001	E -20-1	16
S40567001	J -1	20
S40569001	J -14	20
S40570001	M -120	30
S40571001	M -122	30
S40572001	M -116	30
S40574009	Z -90	40
S40640001	Z -90-7	40
S40641001	Z -90-15	40
S40643001	Z -90-16	40
S40977001	J -5	20
S44908001	L -1	26
S44909001	L -4	26
S44910001	L -12	26
014060632	Z -90-16-1	40
014680422	B -54	6
	D -40-2-11	12
	J -15	20
	M -6	28
	M -71	28
	M -117	30
	M -137	30
	M -141	30
014680622	B -43	6
	B -45	6
	G -4	8
	J -21	20

索引 / INDEX / VERZEICHNIS
/ INDEX / INDICE

CODE	REF.NO.	Page
014680622	K -17	22
014710522	a -1-1-17	36
014760622	B -15	6
	B -18	6
	D -26	10
	N -8	32
014770622	B -2	6
	B -5	6
	B -7	6
	B -13	6
	B -50-1	6
	E -46-1	14
	E -47-1	16
	H -9	18
	H -12	18
	H -15	18
	J -24	20
	J -28-1	20
	K -2	22
	M -45-1	28
	N -12	32
014780622	E -43	14
	H -2	18
017711412	L -40	26
017711612	D -15	10
017781412	E -67	16
	K -4	22
018060822	A -13	2
018061222	b -1-2	38
018061631	a -1-1-7	36
018062022	N -4	32
018081622	A -140	4
018400832	a -1-1-4	36
018401422	M -45-2	28
018501022	E -71-1	16
018501222	N -5	34
018505022	b -1-4	38
018680822	M -41	28
	M -97	28
018681022	B -36	6
	B -52	6
	L -5	26
	L -22	26
018771432	D -10	10
	E -7	14
	E -48	16
	E -50	16
	E -54-2	16
	E -57-1	16
	H -7	18
	J -2	20
	J -12	20
	M -47	28
	M -55	28
021080106	Z -135	40
	Z -143	42
	a -1-3	36
021080302	N -1-4	34
	N -84	34
	a -1-1-2-3	36
	a -1-1-10	36
	a -1-7	36
	b -1-6	38

CODE	REF.NO.	Page
021400106	Z -23	42
021400164	a -16-10	36
021500106	Z -90-10-3	40
	Z -90-15-1	40
	Z -90-16-2	40
021630102	D -40-1-5	12
	D -40-3-5	12
021670202	D -40-2-7	12
025030232	A -90-5	2
025040233	a -16-8	36
025050232	A -90-8	4
025080232	N -1-6	34
	a -1-1-2-4	36
025080236	a -1-5	36
025080336	Z -133	40
	Z -141	42
025350236	N -55	32
025350332	K -3-2	22
025680133	A -83	2
025770232	E -66	16
028040243	a -16-9	36
028050246	A -90-7	4
	Z -90-10-2	40
028080242	Z -134	40
	Z -142	42
	a -1-4	36
032422505	b -7-2	38
032461606	Z -136	42
034422503	a -17	36
047200642	C -1-2	8
047502242	E -63	16
048030342	M -134	30
048040342	E -9	14
	a -1-1-13	36
048150143	E -1-12	14
060660416	M -112	30
060670512	A -90-10	4
	L -15	26
060670812	M -121	30
060680512	E -81	14
	M -132	30
	N -72	34
060680712	A -91	4
	A -106	4
	D -5	10
	M -95	28
	N -46	32
	N -58	32
	N -62	32
	N -64	32
060681612	A -49	2
062020805	N -60	32
062301616	N -66	34
062303012	N -87	34
062350612	M -130	30
062401006	a -16-7	36
062401406	Z -24	42
062501406	Z -90-15-4	40
062630412	L -13	26
062630612	D -40-1-3	12
	D -40-3-3	12
	J -34	20
062660412	J -4	20

CODE	REF.NO.	Page
062660512	A -90-4	2
	E -1-8	14
062660712	E -54-1	16
062670412	D -40-2-13	12
062670512	M -99	30
	M -109	30
	M -126	30
	M -143	30
062670612	A -136	4
	B -21	6
	K -8	22
	K -10	22
	K -14	22
	K -23	22
	K -41	22
	K -51	24
	M -69	28
	M -123	30
	a -1-1-3-3	36
	a -1-1-6	36
	a -1-1-9	36
062670812	D -42	10
	E -19	14
	H -25	18
	K -3-3	22
	L -11	26
062671012	K -3-8	22
	a -1-1-3-2	36
062671212	D -40-1-1	12
	D -40-3-1	12
062680512	N -7	32
062680612	A -51	2
	H -4	18
	M -92	28
062680663	N -70	34
	a -1-1-3-5	36
062680712	L -17	26
	L -30	26
	N -76	34
062680812	A -30	2
	A -101	4
	B -37	6
	K -33	22
	K -43	22
	M -2	28
	M -74	28
062681012	A -4	2
	A -21	2
	A -111	4
	E -31	14
	E -35	14
	M -8	28
	M -58	28
062681212	M -32	28
062681412	A -55	2
	D -29	10
062681612	A -17	2
062710812	A -66	2
062711012	B -10	6
062780812	K -46	22
072600000	H -22	18
081003670	E -12	14
081014670	A -6	2

索引 / INDEX / VERZEICHNIS
/ INDEX / INDICE

CODE	REF.NO.	Page
081032870	H - 18	18
081044070	K - 36	22
087311215	C - 2	8
100025002	E - 1-17	14
100032004	A - 35	2
100064005	B - 16-4-2	6
100251001	E - 5	14
100294002	E - 61	16
100463001	a - 16-3	36
100644005	L - 2	26
	M - 146	30
100645003	A - 80	2
	D - 38	12
	E - 30	14
	K - 44	22
	M - 39	28
	M - 59	28
100666002	Z - 132	40
101118001	b - 4	38
101572101	Z - 4	40
101706001	A - 104-1	4
	E - 40	14
102424004	Z - 44	40
102571003	D - 37	12
102630001	B - 22	6
	a - 1-1-14	36
102843004	A - 41	2
103810002	M - 147	30
104449009	A - 22	2
104450109	A - 23	2
	A - 130	4
104464001	B - 12	6
104521002	N - 11	32
105161004	D - 40-2-8	12
	M - 110	30
	M - 124	30
	M - 127	30
105234003	A - 56	2
	A - 112	4
105237002	L - 7	26
	L - 43	26
105343001	Z - 14	40
105955002	N - 27	32
106129001	A - 90-9	4
106568003	N - 38	32
107153001	B - 17	6
107231002	N - 24	32
107272002	E - 45	14
107407003	A - 109	4
	A - 117	4
	A - 121	4
107419002	N - 45	32
107779001	Z - 13	40
107780001	Z - 21	40
108520009	A - 26	2
109203001	A - 142	4
	E - 62	16
110087001	a - 16-5	36
110140001	N - 18	32
110161006	D - 16	10
	J - 31	20
	L - 41	26
110167001	b - 1-7	38

CODE	REF.NO.	Page
110168001	b - 1-8	38
110641002	A - 141	4
110704001	J - 3	20
110793001	D - 7	10
110813001	M - 12	28
110832009	M - 14	28
111105002	D - 40-2-5	12
112299001	M - 76	30
112300001	M - 75	30
112301001	M - 77	30
112351001	K - 27	22
112359002	K - 30	22
	K - 38	22
112364001	K - 24	22
112467002	K - 3-11	22
112743001	K - 7	22
112754001	K - 53	24
113431002	E - 52	16
114294001	H - 21	18
114967001	a - 16-4	36
114985001	A - 50	2
116016001	Z - 25	42
117143003	N - 21	32
	N - 42	32
	N - 53	32
117466000	Z - 18	40
117516001	A - 122	4
	D - 39	12
117517003	E - 1-16	14
117934009	A - 19	2
118064001	Z - 17	40
118770001	K - 11	22
118837001	Z - 5	40
118853001	B - 14	6
	N - 9	32
120990001	J - 35-1-1	20
123185001	A - 43	2
126863001	Z - 90-3	40
138843001	Z - 90-12	40
140063001	A - 107	4
140165001	E - 1-3	14
140176001	E - 1-15	14
140205001	E - 49	16
140207001	E - 21	16
140209001	E - 23	16
140210001	E - 24	16
140217001	E - 28	14
140313001	J - 35-2	20
140326009	E - 4	14
140327001	E - 14	14
	J - 9	20
140407001	D - 22	10
	D - 32	12
140678000	b - 2-3	38
140759000	Z - 41	40
141183000	A - 103	4
141208001	D - 23	10
141728001	D - 21	10
142026003	a - 16-1	36
142027001	a - 16-2	36
142268001	a - 1-1-8	36
142274009	A - 53	2
142359001	K - 5	22



CODE	REF.NO.	Page
142721001	Z - 8	40
142997001	Z - 90-6	40
143311001	H - 23	18
143312000	H - 24	18
143325001	D - 3	10
143522000	a - 1-1-3-6	36
143564001	E - 51	16
143565001	E - 53	16
143566001	Z - 15	40
143602001	M - 42	28
144053001	E - 1-9	14
144055001	E - 1-10	14
144075001	N - 56	32
144103009	M - 15	28
144104001	M - 18	28
144110001	M - 19	28
144224001	Z - 42	40
144504001	M - 105	30
144505000	M - 106	30
144526001	M - 138	30
	M - 144	30
144619000	K - 3-1	22
144622001	K - 3-5	22
144875001	K - 3-9	22
144876001	K - 3-10	22
145277205	Z - 20	40
145446001	M - 16	28
145472001	D - 24	10
145663001	E - 1-2	14
145688000	B - 20	6
145737001	K - 21	22
146046000	a - 16-11-2	36
146049001	Z - 7	40
146194000	a - 16-11-3	36
146254001	a - 1-6	36
146255000	a - 1-6-1	36
146256001	a - 1-6-2	36
146315009	A - 125	4
146354001	A - 67	2
146401001	E - 1-4	14
146402001	E - 1-5	14
146403001	E - 1-6	14
146404001	E - 1-7	14
146427001	B - 30-1	6
146457001	A - 135	4
146522101	D - 4	10
146528102	E - 1	14
146529001	E - 1-11	14
146530001	E - 1-13	14
146531001	E - 1-14	14
146532001	E - 2	14
146533001	E - 6	14
146538101	E - 13	14
146539000	E - 15	14
146540000	E - 16	14
146544000	E - 20-1-1	16
	E - 20-2-2	16
146547000	E - 41	14
146548101	E - 42	14
146554001	E - 25	14
146555001	E - 26	14
146556001	E - 55	16
146559001	E - 59	16

索引 / INDEX / VERZEICHNIS
/ INDEX / INDICE

CODE	REF.NO.	Page
146560101	E - 60	16
146563001	E - 65	16
146586009	A - 54	2
	A - 110	4
	A - 129	4
146624101	J - 22	20
146741000	E - 39	14
146924000	M - 96-1	28
147318000	E - 3	14
147363000	K - 48	24
147527000	K - 3-7	22
147528100	K - 3-12	22
147529000	K - 3-13	22
147893009	Z - 22	42
147919001	Z - 35	40
148084001	A - 33	2
148425001	J - 1-1	20
	J - 22-1	20
148834001	E - 56	16
148847001	J - 30	20
149247001	Z - 26-1	42
149547000	L - 16	26
149799000	a - 16-11-4	36
150173003	Z - 90-9	40
150174000	Z - 90-7-1	40
150179002	Z - 90-10-1	40
150180001	Z - 90-1	40
150182000	Z - 90-2	40
150185009	Z - 90-11	40
150206002	Z - 90-4-1	40
150335001	Z - 10	40
150645009	M - 4	28
151059001	A - 137	4
151267001	A - 118	4
151429001	K - 9	22
151927001	K - 52	24
153222001	N - 40	32
153484001	E - 11	14
153675001	A - 48	2
153734001	H - 3	18
154574001	D - 36	12
	N - 28	32
154596000	D - 27	10
154841009	A - 24	2
	A - 25	2
154886001	H - 6	18
154956001	D - 9	10
154957001	D - 11	10
154965001	E - 71-2	16
	M - 101	30
	M - 103	30
155144001	E - 17	14
155145000	E - 18	14
155151000	E - 29	14
155162001	M - 56	28
155175001	E - 68	16
155176001	E - 69	16
155177100	E - 32	14
155178001	E - 33	14
155220000	D - 8	10
	M - 48	28
155282101	K - 29	22
155294100	K - 49	22

CODE	REF.NO.	Page
155295001	K - 50	22
155313001	M - 125	30
155510001	M - 107	30
155539000	B - 47	6
	D - 13	10
	J - 6	20
	M - 53	28
156112003	Z - 90-8	40
156309001	Z - 12	40
156887001	A - 32	2
157840000	K - 15	22
158437009	A - 28	4
159150009	A - 7	2
159476000	K - 25	22
	K - 28	22
	K - 31	22
	K - 39	22
159574101	M - 13	28
159874000	N - 86-4	34
	b - 7-1-3	38
159908001	N - 15	32
183796401	a - 1	36
183893001	A - 104	4
220077001	a - 1-1-3-7	36
233193001	N - 73	34
415006002	N - 82	34
525907000	N - 75	34

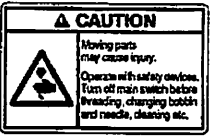
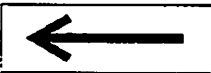
Wa. 警告ラベル / Warning labels / Warningschilder / Etiquettes d'avertissement /
Etiquetas de advertencia

警告ラベル / Warning labels	品名 / Name of Parts	Size(mm)	Code
 <p>△ 注意 動く部分でけがをする。 安全保護装置をつけて 回転作業をすること。 電源を切ってから、糸 通し、ボビンや糸の交換、 掃除や調整をすること。</p>	操作注意ラベル・和	40X64	S38350-001
 <p>△ CAUTION Moving parts may cause injury. Operate with safety device. Turn off main switch before threading, changing bobbin and needle, cleaning etc.</p>	Label, operation Eng.	40X64	S38349-001
	矢印マーク Mark, arrow	10X30	S37058-001
	アースマーク Mark, grounding	φ 12	S37060-001

brother.

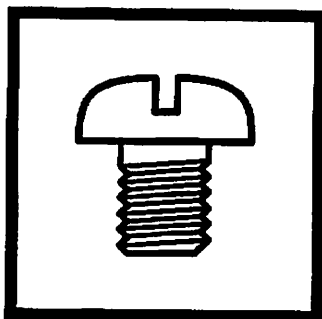

パーツブック
PARTS BOOK
TEILEKATALOG
LIVRE DES PIECES
LIBRO DE REFERENCIA DE PIEZAS

ブラザー工業株式会社

BROTHER INDUSTRIES, LTD.

〒467 名古屋市瑞穂区河岸1丁目1番1号 TEL(052)824-2392

Printed in Japan / Gedruckt in Japan / Imprimé au Japon / Impreso en Japón

118-266
S95266-001
1998.01. H ①